

По вопросам продаж и поддержки обращайтесь:

Алматы (7273)495-231
Ангарск (3955)60-70-56
Архангельск (8182)63-90-72
Астрахань (8512)99-46-04
Барнаул (3852)73-04-60
Белгород (4722)40-23-64
Благовещенск (4162)22-76-07
Брянск (4832)59-03-52
Владивосток (423)249-28-31
Владикавказ (8672)28-90-48
Владимир (4922)49-43-18
Волгоград (844)278-03-48
Вологда (8172)26-41-59
Воронеж (473)204-51-73
Екатеринбург (343)384-55-89
Иваново (4932)77-34-06
Ижевск (3412)26-03-58
Иркутск (395)279-98-46
Казань (843)206-01-48

Калининград (4012)72-03-81
Калуга (4842)92-23-67
Кемерово (3842)65-04-62
Киров (8332)68-02-04
Коломна (4966)23-41-49
Кострома (4942)77-07-48
Краснодар (861)203-40-90
Красноярск (391)204-63-61
Курган (3522)50-90-47
Курск (4712)77-13-04
Липецк (4742)52-20-81
Магнитогорск (3519)55-03-13
Москва (495)268-04-70
Мурманск (8152)59-64-93
Набережные Челны (8552)20-53-41
Нижний Новгород (831)429-08-12
Новокузнецк (3843)20-46-81
Новосибирск (383)227-86-73
Ноябрьск(3496)41-32-12

Омск (3812)21-46-40
Орел (4862)44-53-42
Оренбург (3532)37-68-04
Пенза (8412)22-31-16
Пермь (342)205-81-47
Петрозаводск (8142)55-98-37
Псков (8112)59-10-37
Ростов-на-Дону (863)308-18-15
Рязань (4912)46-61-64
Самара (846)206-03-16
Санкт-Петербург (812)309-46-40
Саранск (8342)22-96-24
Саратов (845)249-38-78
Севастополь (8692)22-31-93
Симферополь (3652)67-13-56
Смоленск (4812)29-41-54
Сочи (862)225-72-31
Ставрополь (8652)20-65-13
Сургут (3462)77-98-35

Сыктывкар (8212)25-95-17
Тамбов (4752)50-40-97
Тверь (4822)63-31-35
Тольятти (8482)63-91-07
Томск (3822)98-41-53
Тула (4872)33-79-87
Тюмень (3452)66-21-18
Улан-Удэ (3012)59-97-51
Ульяновск (8422)24-23-59
Уфа (347)229-48-12
Хабаровск (4212)92-98-04
Чебоксары (8352)28-53-07
Челябинск (351)202-03-61
Череповец (8202)49-02-64
Чита (3022)38-34-83
Якутск (4112)23-90-97
Ярославль (4852)69-52-93

Россия +7(495)268-04-70

Казахстан +7(7172)727-132

Киргизия +996(312)96-26-47

<https://abbdrives.nt-rt.ru/> || aei@nt-rt.ru

ПРОМЫШЛЕННЫЕ ПРИВОДЫ

Техническое описание на

модули

ACS880-304, ACS880-304LC



The all-compatible ACS880 series

Uncompromized productivity

The ACS880 is an all-compatible ABB industrial drive, offered in a range of wall-mounted drives, drive modules and cabinet-built drives.

ABB's all-compatible drives are designed to provide customers across industries and applications with unprecedented levels of compatibility and flexibility. Our ACS880 drive modules are optimized for panel building. They are customized to meet the particular needs of specific industries, such as oil and gas, mining, metals, chemicals, cement, power plants, material handling, pulp and paper, sawmills, marine, water and wastewater, food and beverage, and automotive. They can control a wide range of applications, including cranes, extruders, winches, winders, conveyors, mixers, compressors, centrifuges, test benches, elevators, extruders, pumps and fans.

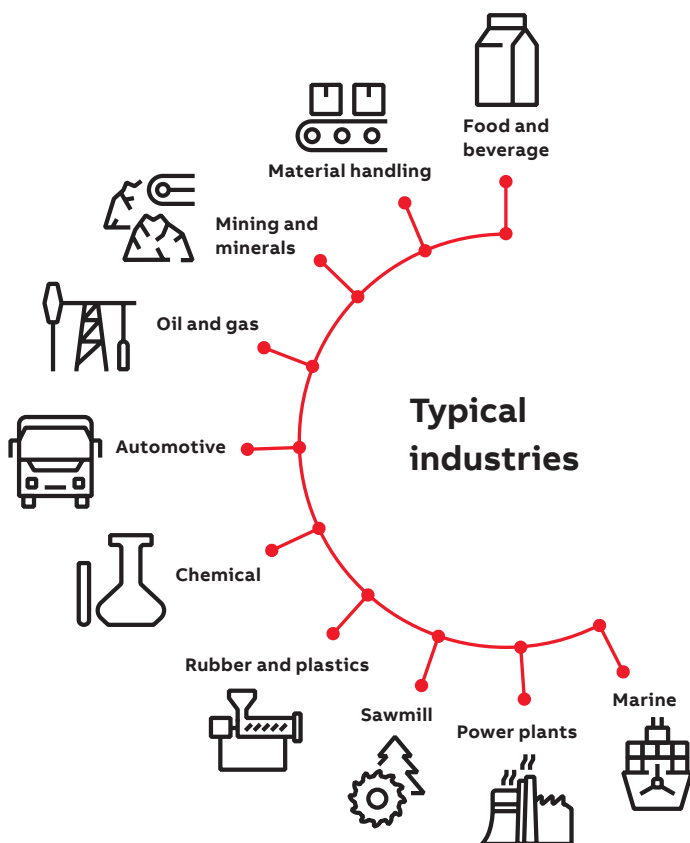

High quality

Reliability and consistent high quality

ACS880 drives are designed for customers who value high quality and robustness in their applications. They have features such as coated boards, making the ACS880 suitable for harsh conditions. Additionally, every ACS880 drive is factory-tested at full load to ensure maximum reliability. The tests include performance and all protective functions.

High performance, safety and configurability

The ACS880 offers the highest level of performance. The drives are equipped with ABB's signature direct torque control (DTC), which provides precise speed and torque control for all applications and supports virtually any type of motor.

Extensive ACS880 offering includes wall-mounted drives, drive modules and cabinet-built drives, as well as low harmonic and regenerative variants.

The ACS880 has all the essential features built-in reducing the time required for engineering, installation and commissioning. A wide range of options are also available to optimize the drive for different requirements, including certified, integrated safety features.

Simplify your world without limiting your possibilities

The ACS880 industrial drive modules are designed for cabinet installation, with features such as optimized location of the power terminals and wheels for easy maneuvering. A wide selection of module variants and options, as well as extensive programming and connectivity possibilities, make the ACS880 suitable for various different requirements and applications.



Optimized for cabinet assembly

- Flexible mounting directions and product configurations
- Side-by-side mounting
- Power terminal locations designed for optimal and compact cabinet layout
- High power modules with wheels for easy maneuvering
- Possibility for flange (push through) mounting
- Mechanical kits for easy cabinet assembly

See page 8



Ease of engineering and use

- All-compatible ACS880 drives share the same easy-to-use user interface
- Multilingual control panel with clear display
- Graphical PC tools for engineering, commissioning and maintenance
- Minimized engineering and installation effort with integrated features and components
- Extensive selection of support material and tools for engineering
- Virtual commissioning

See page 9



Ensure the safety of your machinery and processes with drive-based functional safety

- Safe torque off built-in as standard
- Optional safety modules for extended safety functions
- Encoderless safe speed detection
- Highest level of machinery safety, SIL 3 / PL e
- TÜV certified

See page 14



Fieldbus and Industrial Ethernet solutions

- Communication with all major fieldbus protocols
- Remote monitoring
- Drivetune mobile app
- Integration tools for various PLCs

See page 12





Nine-year maintenance interval

Minimized downtime

- Robust, long lifetime design for maximum reliability
- Coated circuit boards for harsh conditions
- Removable memory unit for fast drive replacement
- Each drive factory-tested at full load
- Nine-year maintenance interval
- Worldwide service and support
- Advanced features for analyzing and resolving issues

See page 13



Global compatibility with various demands

- Global product approvals, e.g. CE, UL, cUL, CSA, marine certifications, ATEX
- Support for various motor types
- Low harmonic content
- Possibility for regeneration

See page 15



Premium control and programmability

- Direct torque control (DTC) for precise control
- Speed, torque and position control as well as synchronizing
- Extensive parameter-based programming
- Adaptive programming as standard
- Drive-based PLC programmability (IEC 61131-3) for fully customized solutions

See page 16



Application- and industry specific solutions

- Ready-made optimized solutions for various applications and industries

See page 18 – 19



Optimized for cabinet assembly

Optimized mechanical design for cabinet assembly

ACS880 drive modules have been optimized for assembly into the customer's own cabinets to ensure high quality and compact installation at minimal cost. High power modules have wheels for easy maneuvering, and the power terminal locations have been designed for optimal and compact cabinet layout. Side-by-side mounting reduces the required cabinet space.

For harsh environments, flange mounting (push through) with IP55 back side protection is offered for complete drive modules. In flange mounting, the control electronics are separated from the cooling airflow for better thermal management and higher reliability.

Flexible mounting and cabling directions enable adaptation to various cabinet enclosures. All the complete ACS880 drive modules have IP20 enclosure class to minimize engineering and assembly effort, as well as to reduce the total cost and ensure a safe ready-made cabinet.

Support for cabinet assembly

A large variety of support material is available for making cabinet assembly, planning and implementation as straightforward and rapid as possible. Cabinet assembly accessories help shorten engineering and assembly time, and help to reduce the risk of errors.

A wide selection of both mechanical and electrical installation accessories are offered for high power modules. These accessories are available giving full design to install the modules into customer enclosures. Alternatively, ABB authorized and registered system integrators and panel builders can offer their assistance.



Ease of engineering and use

All-compatible user interface saves commissioning and learning time

The ACS880 is part of ABB's all-compatible drives portfolio. Other drives in this portfolio are the ACS380, ACS480 and ACS580.

ABB has a wide range of user interface options, which are intuitive and easy to use and provide a superior experience compared to traditional tools.

The drives also share the same communication options, simplifying the use of drives and spare parts handling.

Simplicity at your fingertips as standard

As the standard, the ACS880 drive has a control panel with built-in Bluetooth interface, which enables wireless connection with the ABB Drivetune mobile app and with the entry-level Drive Composer PC tool for startup, commissioning, maintenance, and remote support. Control panel has built-in USB port, which enables PC connection using the Drive Composer software for comprehensive commissioning and maintenance.

Drive Composer is designed for the daily operation of the ACS880 drives. It provides extensive drive monitoring capabilities and quick access to drive settings, as well as features like a graphical interface for configuring safety functions, visual control diagrams, and direct links to user manuals.

Built-in features simplify ordering and installation

All ACS880 drives have a choke for harmonic filtering, a Modbus RTU fieldbus interface, and safe torque off functionality as standard. Other built-in features, standard or optional, include EMC filters, brake units, du/dt filters, low harmonic or regenerative functionality and various I/O extensions, communication protocol adapters, and functional safety modules.

The built-in features shorten engineering and installation time as well as reduce the risk of errors. As result, the total cost is lower and the whole drive system is more compact.

Engineering support

ABB provides an extensive selection of support material and tools to help in engineering, such as:

- Dimensioning tools, e.g. DriveSize
- Step by step installation instructions
- E-learning
- Safety circuit design tools
- EPLAN P8 macros
- Selection tool for choosing external components, e.g. fuses and circuit breakers
- Dimensional (2D and 3D) and electrical drawings
- Application guides
- Drive installation and configuration videos

These tools and support from our experts ensure that the drive system can be set up easily and reliably.

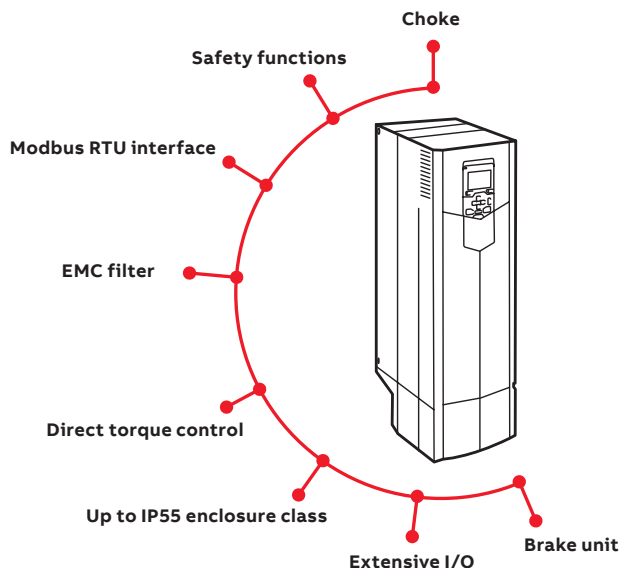

DriveSize dimensioning tool for selecting the optimal drive

DriveSize is designed to help select the optimal drive, motor and transformer for the application. Based on data supplied by the user, the tool calculates and suggests which drive and motors to use.

DriveSize is a free software and can be used either online or downloaded for PC from

Ensure the safety of your machinery and processes with drive-based functional safety

Maximized safety and conformity

The safe torque off (STO) safety function comes integrated into ACS880 drives. Optional safety functions modules provide an easy way to extend safety functions. These plug-in modules are installed and cabled inside the drive, enabling safety functions and diagnostics in one compact and reliable module. The safety functions are certified by TÜV Nord and comply with the highest performance requirements in machinery safety – SIL 3 / PL e *).

Increased productivity by doing things smarter

Safety functions help to minimize unnecessary downtime by keeping the application in control at all times. Safely-limited speed (SLS), for example, keeps the process running at a safe speed instead of stopping it.

Flexibility and ease of use

The safety functionality can be scaled to your needs. From STO wired to an emergency stop push button, to a complete safety system with PROFIsafe and a safety PLC, e.g. the AC500-S.

Configuring the safety functions module is easy thanks to the graphical user interface of the Drive Composer pro PC tool.

Available safety functionality

The following safety functions are supported:

- Safe torque off (STO)
- Safe stop 1 (SS1-t and SS1-r)
- Safe stop emergency (SSE)
- Safe brake control (SBC)
- Safely-limited speed (SLS)
- Safe maximum speed (SMS)
- Prevention of unexpected startup (POUS)
- Safe direction (SDI)
- Safe speed monitor (SSM)
- Safe motor temperature (SMT)

Integrated safety simplifies configuration

Safety for explosive atmospheres

ACS880 and ABB Ex motors have been certified as a package providing a safe, proven solution for explosive atmospheres. ACS880 safety options for ATEX environments:

- ATEX-approved thermistor protection module
- ATEX-approved safe torque off

TÜV-certified safety design tool

The FSDT-01 functional safety design tool can be used to design complete safety circuits. With this tool it is possible to define required safety integrity (SIL) / performance level (PL) for safety functions, verify achieved safety level and generate design reports.

*) SIL 2 / PL c for SMT, safe motor temperature.



Premium control and programmability

Direct torque control (DTC)

ABB's state of the art motor control technology provides precise speed and torque control, with or without an encoder, even close to zero speed. DTC provides reliable starts and rapid reactions to load or network changes, and ensures smooth and continuous operation. DTC provides optimal control, even with sine filters.

The energy optimizer feature maximizes motor efficiency by ensuring maximum torque per ampere, reducing the power drawn from the supply.

Position control and synchronizing

Position control allows to meet motion systems demands without the need of an external position controller. The ready-made motion functions can be easily configured by parameters. For optimized solution for your application, the functions can be modified and extended by IEC 61131 programming using PLCopen motion blocks.

Additional features, such as built-in synchronized drive to drive link and possibility for encoderless positioning, make ACS880 position control ideal for any axis.

Drive programming

To meet your specific application needs, you can customize your ACS880 with an extensive range of user-definable software settings (parameters) and adaptive programming. This makes fine-tuning the ready-made application control program functionalities easy. For further customization, drive application programming based on IEC 61131 standard is available for full PLC programmability. IEC programming uses the same programming environment as ABB PLCs. It is also easy to integrate the ACS880 with other components, such as PLCs and HMIs.

Adaptive programming is

an easy to use dynamic programming which allows flexible adjustments to the ACS880 software.

IEC programming

based on IEC 61131 standard for full scale PLC programmability is available as an option.

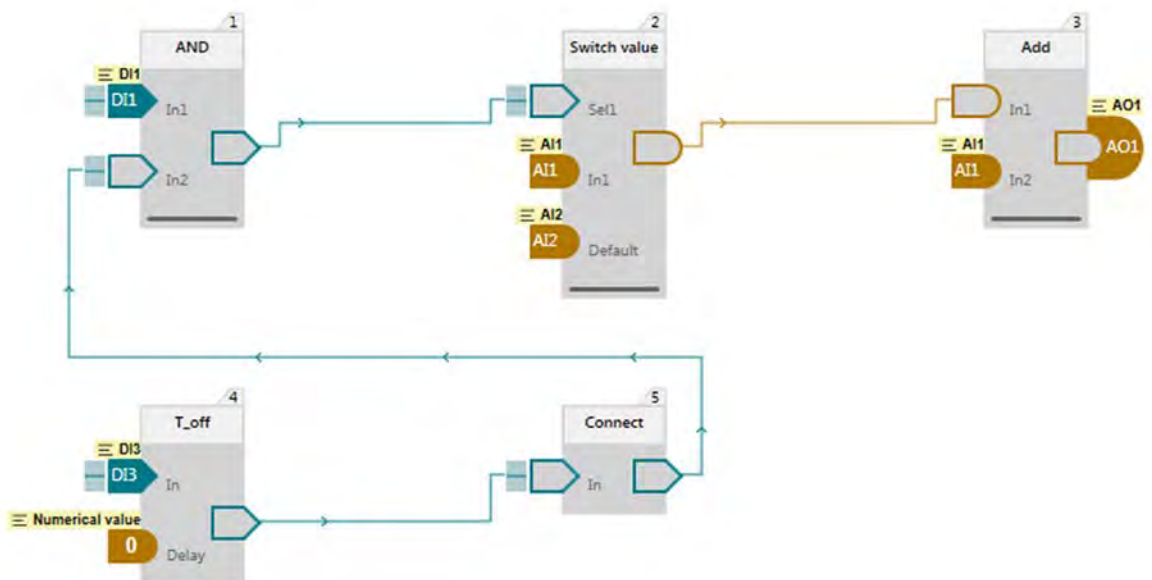

Application- and industry-specific solutions

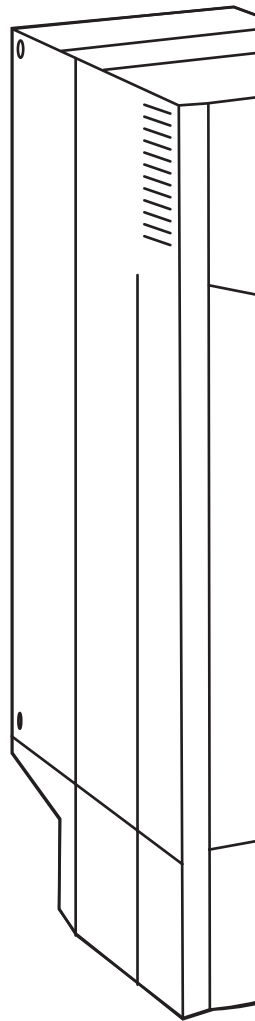
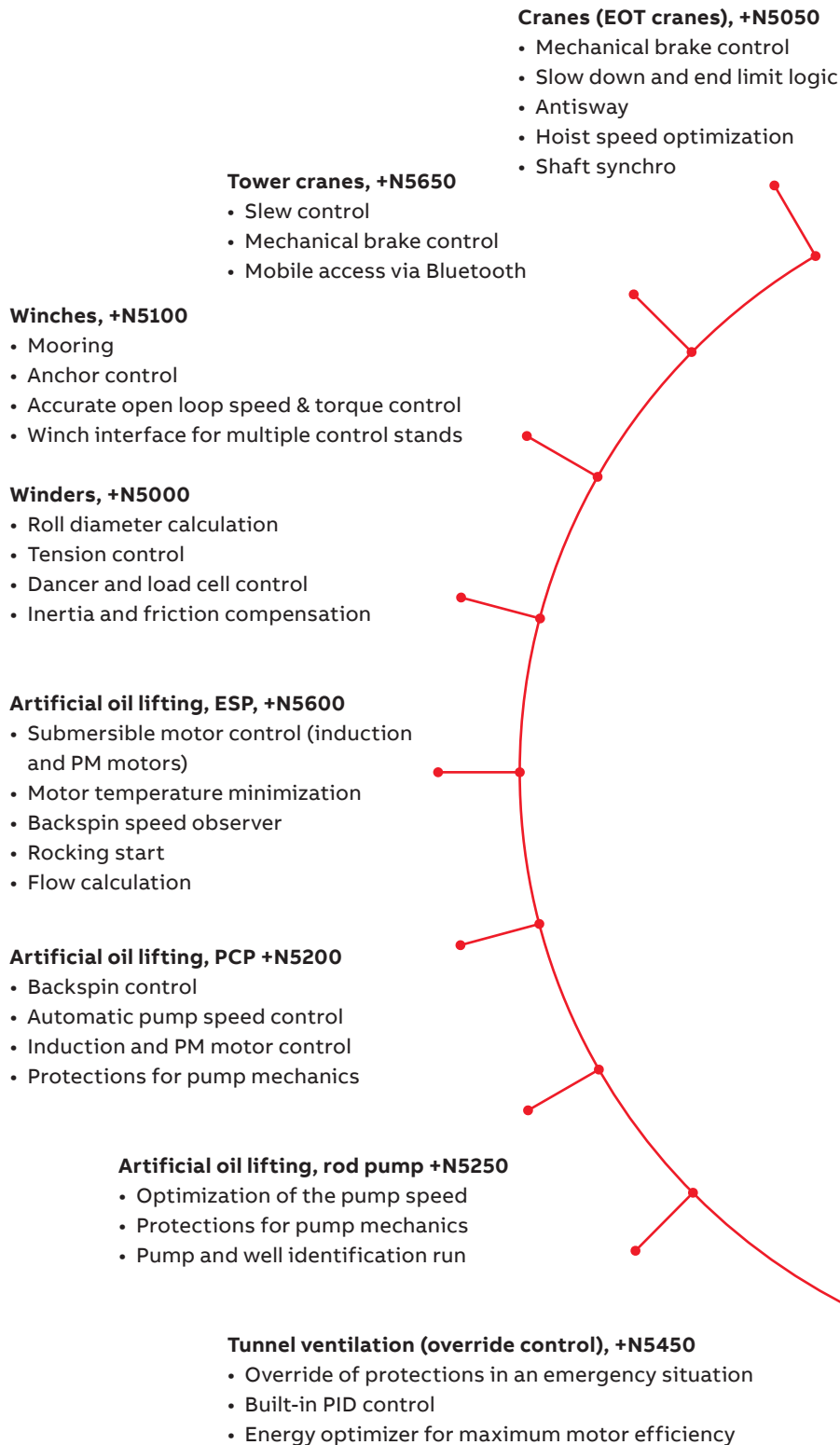

By working closely with customers over many years, ABB has developed application control programs and specific software features for specific applications and industries. This results in programs and features that include lessons learned from many customers, and that are designed to give you the flexibility to adapt the programs to your specific needs.

Advantages:

- Enhanced application usability
- Lower energy consumption
- Increased safety
- Reduced need for PLCs
- Protected machinery
- Optimized application productivity
- Optimized time usage and lower operational costs

Anticavitation, +N5900

- Extend the pump lifetime and secure the process
- Detects cavitation and ensures optimal pump speed to remove it

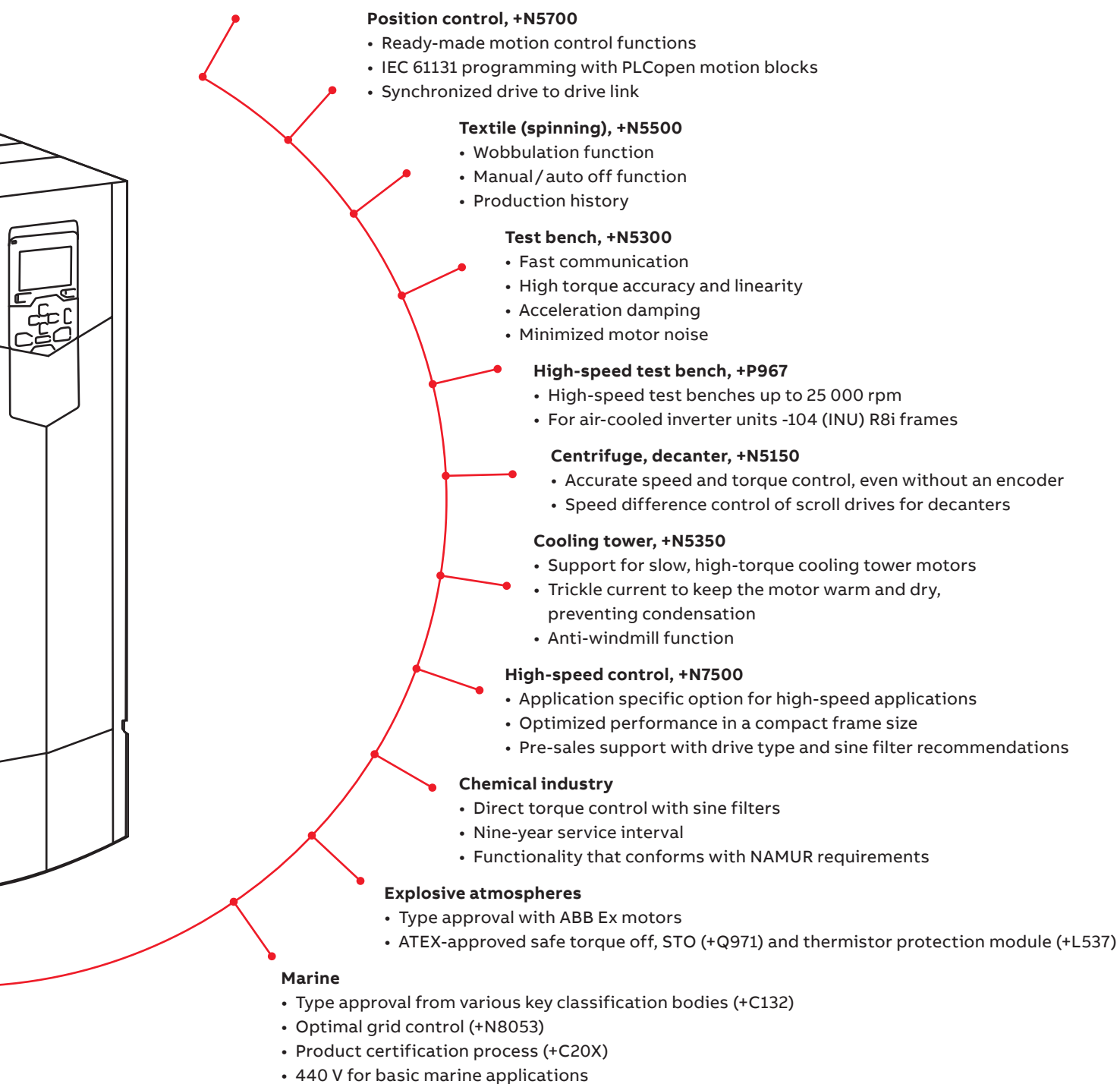

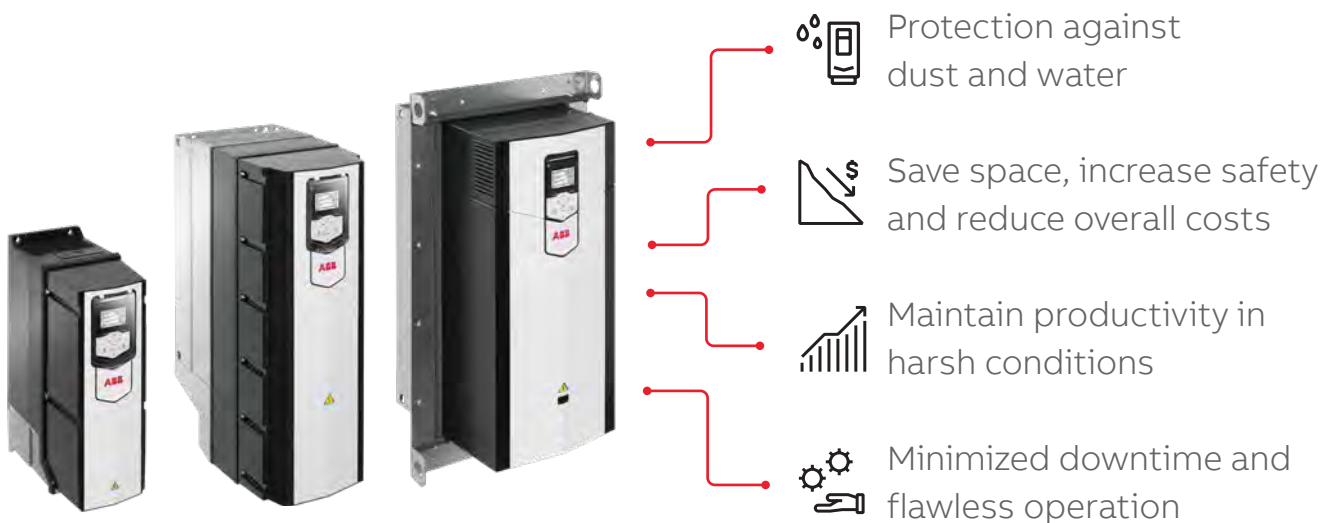

Higher enclosure class and flange-mounted drives for installations in harsh conditions

Don't let dust, moisture or dirt interrupt your processes and drag down productivity. ACS880 IP55/IP54/UL Type 12 units, flange-mounted drives and Rittal VX25 cabinet accessories helps keeping your systems running even in tough conditions.



 Protection against dust and water

 Save space, increase safety and reduce overall costs

 Maintain productivity in harsh conditions

 Minimized downtime and flawless operation

Higher enclosure class for rough environments

The ACS880 IP55/IP54/UL Type 12 units are an ideal choice for harsh environments, where impurities, such as dust or dirt waft in the air. Typical harsh environments include mining, cement, oil and gas, chemical, metal and wood processing industries and harsh outdoor conditions in desert and tropical environments. Higher protection class ensures smooth processes by reducing downtime.

The ACS880-01/-11/-31 units can be installed directly on the wall closer to the motor, which provides flexibility and simplifies installation. The robust, protective design ensures that no additional enclosures or components, such as dust filters and fans, are needed.

ABB does not offer enclosures for potentially explosive atmospheres. ACS880LC liquid cooled modules can be installed to such 3rd party enclosures, as they are 100% liquid cooled.

Be productive, save money and keep it simple

If the environment around your processes includes impurities, drives with lesser enclosure ratings are more likely to fail because they are not designed for harsh environments. A failure causes an interruption and instantly cuts down productivity and adds costs. Robust proven design, coated control boards, plated busbars, and IP55/IP54/UL Type 12 enclosure class ^{*)} or flange mounting ^{*)} combined with proper cabinet design ^{*)} = option), and fully gasketed control panel section that maintains the IP rating even if the control panel is removed help keep your processes up and running in tough environments.

Installing the drive closer to the motor allows shorter motor cables to be used. Shorter cables not only cost less and are easier to handle, but they make it easier to fulfill EMC requirements and reduce the need for additional filters.

Option code	Description
+B056	IP55/UL Type 12 unit (ACS880-01, -11, -31)
+B055	IP54/UL Type 12 unit (ACS880-07, -17, -37, -07CLC, -17/37LC)
+C131	Vibration dampers (ACS880-01, -11, -31)
+C135	Flange mounting (ACS880-01, -11, -31)

Please contact ABB for Rittal VX25 cabinet accessories

Technical data

Mains connection	
Voltage and power range	3-phase, U_{N2} 208 to 240 V, +10%/-15% (-01) 3-phase, U_{N3} 380 to 415 V, +10%/-15% (-01, -04, -04F, -11, -31, -14, -34) 3-phase, U_{N5} 380 to 500 V, +10%/-15% (-01, -04, -04F, -11, -31, -14, -34) 3-phase, U_{N7} 525 to 690 V, +10%/-15% (-01, -04, -04F, -14, -34) 3-phase, U_{N3} 380 to 415 V, $\pm 10\%$ (-x04, -x4 ³⁾) 3-phase, U_{N5} 380 to 500 V, $\pm 10\%$ (-x04, -x4 ³⁾) 3-phase, U_{N7} 525 to 690 V, $\pm 10\%$ (-x04, -x04LC, -x4 ³⁾) ACS880-01, -04, -04F, -11, -31, -14, -34, -x4 ³⁾ , -104, -104LC: 0.55 to 3200 kW Diode supply unit (DSU) 55 to 5445 kVA IGBT supply unit (ISU) 5.5 to 3679 kVA Regenerative rectifier unit (RRU) 400 to 4135 kVA
Frequency	50/60 Hz $\pm 5\%$
Power factor	ACS880-01, -04, -04F $\cos\phi = 0.98$ (fundamental) $\cos\phi = 0.93$ to 0.95 (total)
ACS880-11, -31, -14, -34	$\cos\phi = 1$ (fundamental)
IGBT supply unit (ISU)	$\cos\phi = 1$ (fundamental) $\cos\phi = 0.99$ (total)
Diode supply unit (DSU) and Regenerative rectifier unit (RRU)	$\cos\phi = 0.98$ (fundamental) $\cos\phi = 0.93$ to 0.95 (total)
Efficiency	ACS880-01, -04, -04F, -104, DSU, RRU: 98%. ACS880-11, -31, -14, -34, ISU: 97%
Motor connection	
Voltage	3-phase output voltage 0 to $U_{N2} / U_{N3} / U_{N5} / U_{N7}$
Frequency	0 to ± 598 Hz ¹⁾
Motor control	Direct torque control (DTC)
Torque control	Torque step rise time: Open loop <5 ms with nominal torque Closed loop <5 ms with nominal torque Non-linearity: Open loop $\pm 4\%$ with nominal torque Closed loop $\pm 3\%$ with nominal torque
Speed control	Static accuracy: Open loop 10% of motor nominal slip Closed loop 0.01% of nominal speed Dynamic accuracy: Open loop 0.3 to 0.4% seconds with 100% torque step Closed loop 0.1 to 0.2% seconds with 100% torque step
Product compliance	
CE, UKCA Low Voltage Directive 2014/35/EU according to EN 61800-5-1:2007+A1:2017+A11:2021 SGS statement according to IEC 61800-5-1 Machinery Directive 2006/42/EC EMC Directive 2014/30/EU ATEX Directive 2014/34/EU, EN 50495 Quality assurance system ISO 9001 and Environmental system ISO 14001 RoHS 2011/65/EU and Delegated Directive (EU) 2015/836 Ecodesign Directive 2009/125/EC and its implementation regulation 2019/1781/EU cULus listed according to UL508C or UL 61800-5-1 and CSA C22.2 No. 274 (pending for ACS880-1604LC), CSA Certified according to CSA C22.2 No. 274 (pending for liquid-cooled modules RCM, EAC ⁴⁾ TÜV Nord certification for functional safety ⁵⁾ ATEX-certified safe disconnection function and thermistor protection function, Ex II (2) GD ⁷⁾ UKEX Type Examination certificates for safe disconnection function and thermistor and PT100 protection functions, Ex II (2) GD ^{2) 7)} Marine type approvals: ABS, BV, CCS, ClassNK, DNV GL, KR, LR, RINA For product specific availability,	
EMC according to EN 61800-3: 2004 + A1: 2012. See page 93.	
1 st environment category C2 included as option (-01, -04, -04F, -x4 ³⁾ , -11 ⁹⁾ , -31 ⁹⁾ , -14, -34, -x04).	
2 nd environment category C3 included as standard (-x04, -x04LC, -x4 ³⁾)	
2 nd environment category C3 included as option (-01, -04, -04F, -11, -31, -x4 ^{2) 3)} , -14, -34)	
2 nd environment category C4 included as standard	

Environmental limits	
Ambient temperature	
Transport	-40 to +70 °C
Storage	-40 to +70 °C
Operation area (air-cooled)	-15 to +40 °C as standard (-01, -04, -04F, -11, -31, -14, -34) 0 to +40 °C as standard (-x04, -x4 ³⁾) +40 to +55 °C with derating of 1%/1 °C (-01, -04, -04F, -11, -31, -14, -34) +40 to +50 °C with derating of 1%/1 °C (-x04, -x4 ³⁾)
(liquid-cooled)	0 to +45 °C as standard (-x04LC) +45 to +55 °C with derating of 0.5%/1 °C (-x04LC)
Cooling method	
Air-cooled	Dry clean air
Liquid-cooled	Direct liquid cooling, Antifrogen® L Incoming coolant temperature to module (x04LC): 0 to +40 °C as standard +40 to +45 °C with derating of 2%/1 °C +45 to +50 °C with derating of 2%/1 °C or 6%/1 °C ⁸⁾ Incoming coolant temperature to optional liquid-cooling unit (-1007LC) (fresh water or sea water): 0 to +36 °C as standard +36 to +46 °C with derating of 2%/1 °C
Altitude	
0 to 1,000 m	Without derating
1,000 to 4,000 m	With derating of 1%/100 m ⁶⁾
Relative humidity	
5 to 95%, no condensation allowed	
Degree of protection	
IP00	-x4 ³⁾ , -x04, -x04LC
IP20	-01, -04, -04F, -11, -31, -14, -34
Paint color	
RAL 9017/9002	
Pollution degree	
PD 2	
Contamination levels	
No conductive dust allowed	
Storage	
IEC 60721-3-1:1997, Class 1C2 (chemical gases), Class 1S2 (solid particles) ^{*)}	
Operation	
IEC 60721-3-3:2002, Class 3C2 (chemical gases), Class 3S2 (solid particles) ^{*)}	
Transportation	
IEC 60721-3-2:1997, Class 2C2 or 3C2 (chemical gases), Class 2S2 (solid particles without air inlet filters) ^{*)}	
Built-in functional safety. See pages 90-91.	
For safe torque off (STO) and safety functions module	EN/IEC 61800-5-2, IEC 61508: SIL 3, IEC 61511: SIL 3, EN/IEC 62061 EN ISO 13849-1: PL e - TÜV Nord certified ⁵⁾
Safety over fieldbus	PROFIsafe over PROFINET, certified.
*) C = Chemically active substances, *) S = Mechanically active substances	
1) For higher operational output frequencies please contact your local ABB office. Operation above 120 Hz might require type specific derating, please contact your local ABB office. Output filters may limit the output frequency. See product specific hardware manual for details.	
2) Please check availability per drive type	
3) Single drive module packages ACS880-04, -14 and -34 which consist of several modules	
4) EAC directives: TR CU 020/2011 (EMC directive); TR CU 004/2011 (low voltage directive) EAC has replaced GOST R	
5) For available certificates,	
6) Derating reduced by lower than 40 °C ambient temperature	
7) Safe disconnection function (+Q971), thermistor protection function (+L537)	
8) See product specific hardware manual for detailed derating rules.	
9) Please check availability for -11 and -31 frame size R8.	

Multidrive modules

ACS880-X04

The module selection for building multidrive configurations includes inverter, diode supply, IGBT supply, regenerative rectifier, brake and DC/DC converter units. Their modular design and side-by-side mounting make installation fast and easy. Modules with bigger frame sizes are equipped with wheels so they can easily be moved in or out of the cabinet for maintenance purposes. This concept also allows pre-installation of the power cables inside the empty cabinet.

Multidrive can be used wherever several motors form part of a single process. With a compact module design and high power density, the single supply and DC bus arrangement with multiple inverters provides many advantages:

- Savings in cabling, installation and maintenance costs
- Reduced component count and increased reliability
- Reduced line power and line currents. As the energy circulates over the common DC bus, all energy is not taken from the supply network. Energy circulation can be used for motor-to-motor braking without the need for a braking unit or regenerative supply unit.

Inverter units (INU)

Inverter units are DC supplied and have built-in capacitors for smoothing the DC voltage. The electrical connection to the common DC bus is fuse protected. An optional switch can be selected to disconnect the whole drive unit from the DC bus.

Diode supply units (DSU)

A diode supply unit is used in non-regenerative drive systems to convert three-phase AC voltage to DC voltage. Two types of diode supply unit are available: an uncontrolled 6-pulse diode supply unit (D6D to D8D) and a half-controlled diode supply unit with thyristor charging (D7T and D8T). The DXT modules can be connected parallel and are able to charge the inverters without external components.

IGBT supply units (ISU)

IGBT supply units are used in regenerative drives to convert three-phase AC voltage to DC voltage. The units provide the same features as ACS880-11/14 regenerative drives.

The ISU consists of RXi and LCL filter modules. It can operate in both motoring and generating modes. The DC voltage is constant and the line current is sinusoidal. The control also provides a near unity power factor. The supply unit can also boost DC voltage e.g. when line voltage is low. Harmonic content remains extremely low due to DTC control and LCL line filtering. In optimal grid control (OGC, option +N8053) the ISU can generate off-grid network e.g. hotel grid in vessels.

Regenerative rectifier unit (RRU)

This supply unit is used in regenerative drive systems to convert three-phase AC voltage to DC voltage. The RRU consists of R8i and L filter modules. During motoring the input current flows through the diodes to the DC bus and the supply unit works as a diode bridge. In regeneration the current flows from the DC bus through the IGBTs to the supply network. The IGBTs' are switched to conduct only once during each network voltage cycle. This reduces switching losses and enables high input and output powers of the R8i module. Unlike with a thyristor bridge, the IGBTs can be switched off at any time which improves reliability.

Brake unit

Brake unit is used for resistor braking. It handles the energy generated by decelerating motors for example in emergency stopping. Whenever the voltage in the common DC bus exceeds a certain limit, a braking unit connects the bus to a braking resistor.

DC/DC converter (DDC)

This converter can transfer energy from a common DC bus of a drive system into an external energy storage. From there it can transfer the energy back to the DC bus when needed. Energy storages can be batteries or super capacitors. Applications for energy storage and reuse are found in a range of industries, such as marine (heave and peak load compensation), process industry (electrical braking or DC bus voltage stabilization) and automotive (charging systems). The converter unit consists of R8i and DCL filter modules.

—
01
Multidrive configuration
with supply unit, DC bus
and multiple inverters

—
02
ACS880-104 inverters
modules, frame
sizes R1i to R8i

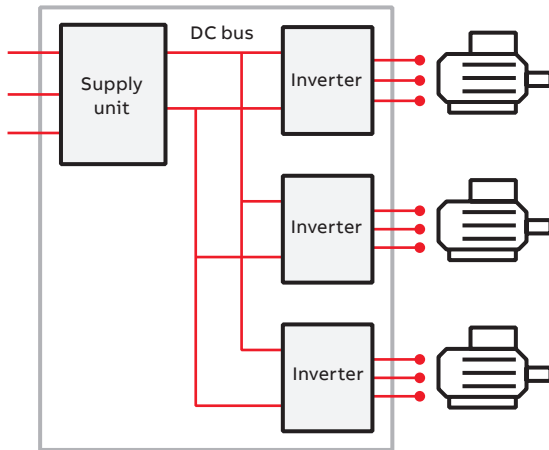

—
01



—
02

Multidrive modules, ACS880-X04

- Power ratings:
 - Inverter units (INU): 1.5 to 3200 kW
 - Diode supply units (DSU): 55 to 5445 kVA
 - IGBT supply units (ISU): 5.5 to 3679 kVA
 - Regenerative rectifier units (RRU): 416 to 4135 kVA
 - Brake units: 1-phase P_{cont} 70 to 714 kW, 3-phase P_{cont} 500 to 6500 kW
 - DC/DC converters (DDC): 305 to 1146 kW
- Voltage range: 380 to 690 V
- Enclosure class: IP00
- All multidrive modules come with a control unit. The same control units are used with all ACS880 drives. They have three option slots for option modules, such as I/O extension and communication protocol adapters.

Main options:

- Detailed documentation for cabinet installation
- Cabinet accessory kits
- Marine type approvals
- I/O extension modules, see page 83
- Communication protocol adapters, see page 83
- Application specific softwares, see page 18
- Speed feedback interfaces, see page 85
- Remote monitoring options, see page 86
- Functional safety modules, see page 90
- Brake unit and resistors, see page 102
- Du/dt filters, see page 110

The drives have an extensive selection of built-in features and options. See page 124.

Highlights

- Compact design for easy cabinet assembly and maintenance
- High power density
- Multidrive concept with one supply unit and DC bus arrangement with multiple inverters which reduces line power, cabinet size and investment costs
- Mechanical and electrical accessories which provide full design to install the modules into Rittal VX25 cabinets

Liquid-cooled multidrive modules

ACS880-x04LC

The compact and robust ACS880 liquid-cooled drive modules with direct liquid cooling are a very good solution for various applications where space savings, silent operation or durability in harsh environments is a must.

Advanced liquid cooling and compact design

Liquid cooling offers easy heat transfer without air filtering problems. Since the coolant takes care of 98% of the heat losses, no additional filtered air cooling is needed. This increases the total efficiency of the drive installation.

The ACS880 liquid-cooled modules have high power density making their design extremely compact. The small footprint enables significant space and weight reduction.

Optimal for harsh environmental conditions

Optimal solution for different environments

The possibility to have totally enclosed cabinet structure makes the ACS880 liquid-cooled modules perfect for harsh environmental conditions. The modules can even be integrated into explosion-proof enclosures for installations in hazardous locations.

The ACS880 liquid-cooled offering fulfills marine and offshore requirements. The modules have marine type approvals from various key classification bodies.

As the direct liquid cooling enables silent operation, the ACS880 liquid-cooled modules are suitable for applications where noise levels are an important environmental factor.

Simple and cost-efficient installation

The high-efficient liquid cooling removes the need for air-conditioning in the installation rooms, bringing the installation and operation costs down. As there is no need for additional air conditioning devices or air ducts, the installation is significantly simplified. Liquid cooling also enables heat recovery when process heat is needed, which can help to reduce CO₂ footprint.

The used coolant type is Antifrogen® L, by Clariant International Ltd, cooling liquid with glycol and inhibitor. It is a ready-made, commercially available mix, which enables easy commissioning and prevents the risk of errors in coolant selection.

Robust, reliable and compact

Wide selection of drive module products

Covering a wide power range with very small footprint, the liquid-cooled ACS880 is available for single and multidrive purposes. The product family includes diode supply units, IGBT supply units, inverter units, DC/DC converters and brake units. In optimal grid control (OGC, +N8053) the IGBT supply unit can generate off-grid network e.g. hotel grid in vessels.

Optional stand-alone liquid cooling units are offered for cooling the modules. All piping and heat exchangers can be combined to the same closed-loop cooling system.

In addition ABB offers an extensive selection of electrical and mechanical installation accessories including piping components. These minimize cabinet engineering and assembly effort and ensure a safe, tested cabinet design.

—
01
ACS880-304LC diode
supply module,
frame D8D
—
02
ACS880-104LC inverter
module, frame R7i
—
03
ACS880-104LC inverter
module, frame R8i.
The same module is
used in -204LC IGBT
supply and -1604LC
DC/DC converter units.



Liquid-cooled modules, ACS880-X04LC

- Power ratings:
Diode supply units (DSU): 585 to 4780 kVA
IGBT supply units (ISU): 311 to 3502 kVA
Inverter units (INU): 55 to 6000 kW
1-phase brake units: 54 to 714 kW
3-phase brake units: 870 to 5200 kW P_{cont}
DC/DC converters: 351 to 1581 kW
- Enclosure class: IP00
- 3-phase inverter modules with internal du/dt filters as standard in all frames
- Quick connectors for motor cable output connection in all inverter modules. Frame R7i has quick connectors also for DC connections.

Main options:

- Support for 6/12/24-pulse network configurations
- Electrical and mechanical installation accessories including piping components – full design for Rittal VX25 cabinet installations
- Wide selection of ACS880 options

Liquid cooling unit, ACS880-1007LC

- Power ratings: 70 to 195 kW cooling power
- Enclosure class: IP54
- Stand-alone cabinet with cooling pipe connections on the right side
- Built-in cabinet heater
- Heat exchanger for industrial cooling water
- Fulfills marine requirements

Main options:

- Single pump and two pump versions
- Redundant pump version
- Different piping solutions and sea water heat exchanger available as engineered variants

The drives have an extensive selection of built-in features and options. See page 128.

Highlights

- Advanced liquid cooling which reduces the need for air cooling in installation rooms
- High power density with compact design
- Optimized design for cabinet assembly
- Silent operation
- Suitable for harsh environments
- Marine approvals from various key classification bodies

Ratings, types and voltages

Supply units, air-cooled, ACS880-304, 400 V

$U_N = 400$ V (range 380 to 415 V). The power ratings are valid at nominal voltage 400 V (5.5 to 3788 kVA).

Drive type	Frame size	Nominal ratings				No over- load use	Light overload use	Heavy- duty use		Noise level (dB(A))	Heat dissi- pation (kW)	Air flow (m ³ /h)	
		I_N AC (A)	I_N DC (A)	I_{max} DC (A)	S_N (kVA)	P_N DC (kW)	I_{Ld} DC (A)	P_{Ld} DC (kW)	I_{Hd} DC (A)				P_{Hd} DC (kW)
Diode supply modules (DSU), ACS880-304													
6-pulse diode ¹⁾													
ACS880-304-0080A-3+A003	D6D	80	98	137	55	53	94	51	78	42	62	0.8	370
ACS880-304-0170A-3+A003	D6D	173	212	297	120	114	203	110	170	92	62	1.3	370
ACS880-304-0330A-3+A003	D7D	327	400	561	227	216	384	208	320	173	62	2	720
ACS880-304-0490A-3+A003	D7D	490	600	840	339	324	576	311	480	259	62	3	720
ACS880-304-0650A-3+A003	D8D	653	800	1120	452	432	768	415	640	345	65	4.5	900
ACS880-304-0980A-3+A003	D8D	980	1200	1680	679	648	1152	622	960	519	65	6	900
ACS880-304-0650A-3+A018	D8T	653	800	1120	452	432	768	415	598	323	72	4.6	1300
ACS880-304-0980A-3+A018	D8T	980	1200	1680	679	648	1152	622	898	485	72	6.6	1300
ACS880-304-1210A-3+A018	2×D8T	1215	1488	2083	842	804	1428	771	1113	601	74	9.2	2600
ACS880-304-1820A-3+A018	2×D8T	1823	2232	3125	1263	1205	2143	1157	1670	902	74	13.3	2600
ACS880-304-2730A-3+A018	3×D8T	2734	3348	4687	1894	1808	3214	1736	2504	1352	76	19.9	3900
ACS880-304-3640A-3+A018	4×D8T	3645	4464	6250	2525	2411	4285	2314	3339	1803	76	26.6	5200
ACS880-304-4560A-3+A018	5×D8T	4557	5580	7812	3157	3013	5357	2893	4174	2254	77	33.3	6500
ACS880-304-5470A-3+A018	6×D8T	5468	6696	9374	3788	3616	6428	3471	5009	2705	78	40	7800
12-pulse diode ¹⁾													
ACS880-304-0910A-3+A004+A018	2×D7T	912	1116	1562	632	625	1071	600	835	467	74	8.4	1800
ACS880-304-1210A-3+A004+A018	2×D8T	1215	1488	2083	842	833	1428	800	1113	623	74	9.2	2600
ACS880-304-1820A-3+A004+A018	2×D8T	1823	2232	3125	1263	1250	2143	1200	1670	935	74	13.3	2600
ACS880-304-2430A-3+A004+A018	4×D8T	2430	2976	4166	1684	1667	2857	1600	2226	1247	76	18.4	5200
ACS880-304-3640A-3+A004+A018	4×D8T	3645	4464	6250	2525	2500	4285	2400	3339	1870	76	26.6	5200
ACS880-304-5470A-3+A004+A018	6×D8T	5468	6696	9374	3788	3750	6428	3600	5009	2805	78	40	7800

Ratings, types and voltages

Supply units, air-cooled, ACS880-304, 500 V

$U_N = 500$ V (range 380 to 500 V). The power ratings are valid at nominal voltage 400 V (5.7 to 4735 kVA).

Drive type	Frame size	Nominal ratings				No over- load use	Light overload use	Heavy- duty use		Noise level	Heat dissi- pation	Air flow	
		I_N AC (A)	I_N DC (A)	I_{max} DC (A)	S_N (kVA)	P_N DC (kW)	I_{Ld} DC (A)	P_{Ld} DC (KW)	I_{Hd} DC (A)	P_{Hd} DC (kW)	(dB(A))	(kW)	(m ³ /h)
Diode supply modules (DSU), ACS880-304													
6-pulse diode¹⁾													
ACS880-304-0080A-5+A003	D6D	80	98	137	69	66	94	63	78	53	62	0.8	370
ACS880-304-0170A-5+A003	D6D	173	212	297	150	143	203	137	170	114	62	1.3	370
ACS880-304-0330A-5+A003	D7D	327	400	561	283	270	384	260	320	216	62	2	720
ACS880-304-0490A-5+A003	D7D	490	600	840	424	405	576	389	480	324	62	3	720
ACS880-304-0650A-5+A003	D8D	653	800	1120	566	540	768	518	640	432	65	4.5	900
ACS880-304-0980A-5+A003	D8D	980	1200	1680	849	810	1152	778	960	648	65	6	900
ACS880-304-0650A-5+A018	D8T	653	800	1120	566	540	768	518	598	404	72	4.6	1300
ACS880-304-0980A-5+A018	D8T	980	1200	1680	849	810	1152	778	898	606	72	6.6	1300
ACS880-304-1210A-5+A018	2×D8T	1215	1488	2083	1052	1004	1428	964	1113	751	74	9.2	2600
ACS880-304-1820A-5+A018	2×D8T	1823	2232	3125	1579	1507	2143	1446	1670	1127	74	13.3	2600
ACS880-304-2730A-5+A018	3×D8T	2734	3348	4687	2368	2260	3214	2170	2504	1690	76	19.9	3900
ACS880-304-3640A-5+A018	4×D8T	3645	4464	6250	3157	3013	4285	2893	3339	2254	76	26.6	5200
ACS880-304-4560A-5+A018	5×D8T	4557	5580	7812	3946	3767	5357	3616	4174	2817	77	33.3	6500
ACS880-304-5470A-5+A018	6×D8T	5468	6696	9374	4735	4520	6428	4339	5009	3381	78	40	7800
12-pulse diode¹⁾													
ACS880-304-0910A-5+A004+A018	2×D7T	912	1116	1562	790	781	1071	750	835	584	74	8.4	1800
ACS880-304-1210A-5+A004+A018	2×D8T	1215	1488	2083	1052	1042	1428	1000	1113	779	74	9.2	2600
ACS880-304-1820A-5+A004+A018	2×D8T	1823	2232	3125	1579	1562	2143	1500	1670	1169	74	13.3	2600
ACS880-304-2430A-5+A004+A018	4×D8T	2430	2976	4166	2104	2083	2857	2000	2226	1558	76	18.4	5200
ACS880-304-3640A-5+A004+A018	4×D8T	3645	4464	6250	3157	3125	4285	3000	3339	2337	76	26.6	5200
ACS880-304-5470A-5+A004+A018	6×D8T	5468	6696	9374	4735	4687	6428	4500	5009	3506	78	40	7800

Ratings, types and voltages

Supply units, air-cooled, ACS880-304, 690 V

$U_N = 690 \text{ V}$ (range 525 to 690 V). The power ratings are valid at nominal voltage 690 V (366 to 5446 kVA).													
Drive type	Frame size	Nominal ratings				No over- load use	Light overload use	Heavy- duty use		Noise level	Heat dissi- pation	Air flow	
		I_N AC (A)	I_N DC (A)	I_{max} DC (A)	S_N (kVA)	P_N DC (kW)	I_{Ld} DC (A)	P_{Ld} DC (kW)	I_{Hd} DC (A)	P_{Hd} DC (kW)	(dB(A))	(kW)	(m ³ /h)
Diode supply units (DSU), ACS880-304													
6-pulse diode¹⁾													
ACS880-304-0570A-7+A018	D8T	572	700	980	684	652	672	626	524	488	72	4.5	1300
ACS880-304-0820A-7+A018	D8T	817	1000	1400	976	932	960	894	748	697	72	5.8	1300
ACS880-304-1060A-7+A018	2×D8T	1064	1302	1823	1272	1213	1250	1164	974	907	74	9	2600
ACS880-304-1520A-7+A018	2×D8T	1519	1860	2604	1815	1733	1786	1663	1391	1296	74	12.7	2600
ACS880-304-2280A-7+A018	3×D8T	2279	2790	3906	2724	2599	2678	2495	2087	1944	76	19.1	3900
ACS880-304-3040A-7+A018	4×D8T	3038	3720	5208	3631	3465	3571	3327	2783	2592	76	25.5	5200
ACS880-304-3800A-7+A018	5×D8T	3797	4650	6510	4538	4331	4464	4158	3478	3240	77	32	6500
ACS880-304-4560A-7+A018	6×D8T	4557	5580	7812	5446	5198	5357	4990	4174	3888	78	38.4	7800
12-pulse diode¹⁾													
ACS880-304-0760A-7+A004+A018	2×D7T	760	930	1302	908	898	893	862	696	672	74	7.7	1800
ACS880-304-1060A-7+A004+A018	2×D8T	1064	1302	1823	1272	1258	1250	1207	974	941	74	9	2600
ACS880-304-1520A-7+A004+A018	2×D8T	1519	1860	2604	1815	1797	1786	1725	1391	1344	74	12.7	2600
ACS880-304-2130A-7+A004+A018	4×D8T	2127	2604	3646	2542	2515	2500	2415	1948	1882	76	18.1	5200
ACS880-304-3040A-7+A004+A018	4×D8T	3038	3720	5208	3631	3594	3571	3450	2783	2688	76	25.5	5200
ACS880-304-4560A-7+A004+A018	6×D8T	4557	5580	7812	5446	5390	5357	5175	4174	4032	78	38.4	7800

Ratings, types and voltages

Supply units, liquid-cooled, ACS880-304LC, 690 V

$U_N = 690$ V (range 525 to 690 V). The power ratings are valid at nominal voltage 690 V (311 to 3663 kVA).

Supply module type	Frame size	Nominal ratings					Light overload use		Heavy-duty use		Noise level ¹⁾ (dB(A))	Losses ²⁾ P_{loss} (kW)	Coolant flow rate (l/min)
		I_N AC (A)	I_N DC (A)	I_{max} DC (A)	S_N (kVA)	P_N DC (kW)	I_{Ld} DC (A)	P_{Ld} DC (kW)	I_{Hd} DC (A)	P_{Hd} DC (kW)			
Liquid-cooled diode supply units (DSU), ACS880-304LC													
6-pulse diode													
ACS880-304LC-0820A-7+A019 ³⁾	D8D	820	1000	1500	980	932	960	895	800	745	63	3.5	12
ACS880-304LC-1540A-7+A019 ³⁾	2×D8D	1540	1880	2820	1840	1752	1805	1682	1504	1401	63	6.6	12
ACS880-304LC-2290A-7+A019 ³⁾	3×D8D	2290	2805	4208	2737	2614	2693	2509	2244	2091	63	9.8	24
ACS880-304LC-3040A-7+A019 ³⁾	4×D8D	3040	3720	5580	3633	3466	3571	3328	2976	2773	63	13	24
ACS880-304LC-0490A-7+A018 ⁴⁾	D8T	490	600	900	585	559	576	537	449	418	65	3.0	14
ACS880-304LC-0780A-7+A018 ⁴⁾	D8T	780	955	1430	932	890	917	854	714	666	65	4.6	14
ACS880-304LC-1060A-7+A018 ⁴⁾	D8T	1060	1300	1950	1267	1211	1248	1163	972	906	65	6.2	14
ACS880-304LC-1470A-7+A018 ⁴⁾	2×D8T	1470	1800	2700	1757	1677	1728	1610	1346	1255	65	8.7	28
ACS880-304LC-2000A-7+A018 ⁴⁾	2×D8T	2000	2450	3675	2390	2283	2352	2192	1833	1708	65	11.7	28
ACS880-304LC-3000A-7+A018 ⁴⁾	3×D8T	3000	3670	5505	3585	3420	3523	3283	2745	2558	67	17.5	42
ACS880-304LC-4000A-7+A018 ⁴⁾	4×D8T	4000	4900	7350	4780	4566	4704	4383	3665	3415	67	23.4	56
12-pulse diode													
ACS880-304LC-0920A-7+A004+A018 ⁵⁾	2×D8T	920	1130	1695	1100	1053	1085	1011	845	788	67	5.6	28
ACS880-304LC-1470A-7+A004+A018 ⁵⁾	2×D8T	1470	1800	2700	1757	1677	1728	1610	1346	1255	67	8.7	28
ACS880-304LC-2000A-7+A004+A018 ⁵⁾	2×D8T	2000	2450	3675	2390	2283	2352	2192	1833	1708	67	11.7	28
ACS880-304LC-2940A-7+A004+A018 ⁵⁾	4×D8T	2940	3600	5400	3514	3355	3456	3220	2693	2509	68	18.0	56
ACS880-304LC-4000A-7+A004+A018 ⁵⁾	4×D8T	4000	4900	7350	4780	4566	4704	4383	3665	3415	68	23.4	56

¹⁾ Noise level in a typical cabinet installation.

²⁾ In totally enclosed cabinet 98% of losses are conducted to coolant, 2% to ambient air.

³⁾ +A019 is option code for direct uncontrolled diode bridge.

⁴⁾ +A018 is option code for half controlled diode bridge.

⁵⁾ +A004 is 12-pulse DSU and +A018 is half-controlled diode bridge.

Nominal ratings

I_N	Rated current available continuously without overloadability
P_N	Typical motor power in no-overload use
S_N	Nominal apparent (AC) power

Maximum output current

I_{max}	Maximum output current. Available for 10 seconds at start, then as long as allowed by module temperature.
-----------	---

Light-overload use

I_{Ld}	Continuous current allowing 110% I_{Ld} for 1 minute every 5 minutes.
P_{Ld}	Typical motor power in light-overload use.

Heavy-duty use

I_{Hd}	Continuous current allowing 150% I_{Hd} for 1 minute every 5 minutes
P_{Hd}	Typical motor power in heavy-duty use.

Losses

P_{loss}	Power loss conducted to coolant and emitted to air
------------	--

The ratings apply at an ambient air temperature of 45 °C and a coolant temperature of 40 °C.

Dimensions

ACS880 drive modules

ACS880-304, air-cooled diode supply modules (DSU), IP00

Frame size	Height (mm)	Width (mm)	Depth (mm)	Weight (kg)
D6D	815	170	415	37
D7D	1054	170	417	73
D8D	1397	240	589	173
D7T	1178	170	417	80
D8T	1397	240	589	180

ACS880-304 frame D8T



ACS880-304LC, liquid-cooled diode supply unit (DSU), IP00

Frame size	Height (mm)	Width (mm)	Depth (mm)	Weight (kg)
D8D	242	170	292	12
D8T	374	339	518	83/86/88 ¹⁾

¹⁾ The weigh of the D8T module varies depending on the nominal current.

ACS880-304LC, D8D

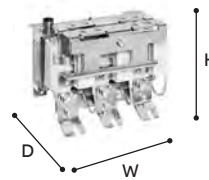

ACS880-304LC, D8T



Standard interface and extensions for plug-in connectivity

—
01 Control unit ZCU
—
02 Example of a typical drive modules input/output connection diagram. Variations may be possible. For further information, please see the ACS880 user manual.

ACS880 drive modules offer a wide range of standard interfaces including extensive selection of I/O connections, Safe Torque Off (STO) and a galvanically isolated RS485 link that can be configured as either Modbus RTU or high-speed drive-to-drive link.

In addition, the drive control unit (ZCU/BCU) has three option slots that can be used for extensions, including communication protocol adapters, input/output extension modules, feedback modules, and a safety functions module. For I/O extensions, see page 81.

External control unit BCU-X2 is used with all parallel connected modules, such as n×R8i, n×DxT, -04XT and 04FXT.



Control connections	Description
2 analog inputs (XAI)	Current input: -20 to 20 mA, R_{in} : 100 ohm Voltage input: -10 to 10 V, $R_{in} > 200$ kohm Resolution: 11 bit + sign bit
2 analog outputs (XAO)	0 to 20 mA, $R_{load} < 500$ ohm Frequency range: 0 to 300 Hz Resolution: 11 bit + sign bit
6 digital inputs (XDI)	Input type: NPN/PNP (DI1 to DI5), NPN (DI6) DI6 (XDI:6) can alternatively be used as an input for a PTC thermistor.
Digital input interlock (DIIL)	Input type: NPN/PNP
2 digital inputs/outputs (XDIO)	As input: 24 V logic levels: "0" < 5 V, "1" > 15 V R_{in} : 2.0 kohm Filtering: 0.25 ms As output: Total output current from 24 V DC is limited to 200 mA Can be set as pulse train input and output
3 relay outputs (XRO1, XRO2, XRO3)	250 V AC/30 V DC, 2 A
Safe torque off (XSTO)	For the drive to start, both connections must be closed
Drive-to-drive link (XD2D)	Physical layer: EIA-485
Built-in Modbus	EIA-485
Assistant control panel/PC tool connection	Connector: RJ-45

Relay outputs		XRO1, XRO2, XRO3		
Ready 250 V AC/30 V DC 2 A	NO COM NC	13 12 11		
Running 250 V AC/30 V DC 2 A	NO COM NC	23 22 21		
Faulted(-1) 250 V AC/30 V DC 2 A	NO COM NC	33 32 31		
External power input		XPOW		
24 V DC, 2 A	GND +24VI	2 1		
Reference voltage and analog inputs		J1, J2, XAI		
AI1/AI2 current/voltage selection	AI1:U AI1:I AI2- AI2+	AI2:U AI2:I 7 6		
By default not in use. 0(4) to 20 mA, $R_{in} = 100 \text{ ohm}$	AI1- AI1+	5 4		
Speed reference 0(2) to 10 V, $R_{in} > 200 \text{ kohm}$	AGND -VREF +VREF	3 2 1		
Ground -10 V DC, $R_L 1 \text{ to } 10 \text{ kohm}$ 10 V DC, $R_L 1 \text{ to } 10 \text{ kohm}$				
Analog outputs		XAO		
Motor current 0 to 20 mA, $R_L < 500 \text{ ohm}$	AGND AO2	4 3		
Motor speed rpm 0 to 20 mA, $R_L < 500 \text{ ohm}$	AGND AO1	2 1		
Drive-to-drive link		J3, XD2D		
Drive-to-drive link termination	ON <input type="checkbox"/> OFF	Shield	4	
Drive-to-drive link or built-in Modbus		BGND	3	
		A	2	
		B	1	
Safe torque off		XSTO		
Safe torque off. Both circuits must be closed for the drive to start.	IN2 IN1 SGND OUT	4 3 2 1		
Digital inputs		XDI		
By default not in use	DI6	6		
Constant speed 1 select (1=on)	DI5	5		
Acceleration and deceleration select	DI4	4		
Reset	DI3	3		
Forward (0)/Reverse (1)	DI2	2		
Stop (0)/Start (1)	DI1	1		
Digital input/outputs		XDIO		
Output: Running	DIO2	2		
Output: Ready	DIO1	1		
Ground selection		XD24		
Digital input/output ground	DIOGND	5		
+24 V DC 200 mA	+24VD	4		
Digital input ground	DICOM	3		
+24 V DC 200 mA	+24VD	2		
Digital interlock	DIIL	1		
Safety functions module connection		X12		
Control panel/PC connection		X13		
Memory unit connection		X205		

Communication and connectivity

Fast and reliable communication

The **F-series fieldbus adapter modules** are flexible, plug-in adapters that provide fast and simple universal connectivity to all major controllers. Universal connectivity means ABB low voltage drives connect to automation controllers and communication networks, allowing users to choose the best network to meet their needs.

- Reduces mechanical and electrical cost
- Decrease in downtime
- Increase in productivity
- Diminished start-up costs
- Lower maintenance and diagnostic costs
- Quick access to networked drives with PC-based start-up and maintenance software tools
- Reductions in wiring costs compared to traditional I/O connections

Industrial automation plant – different network possibilities and their secure deployment

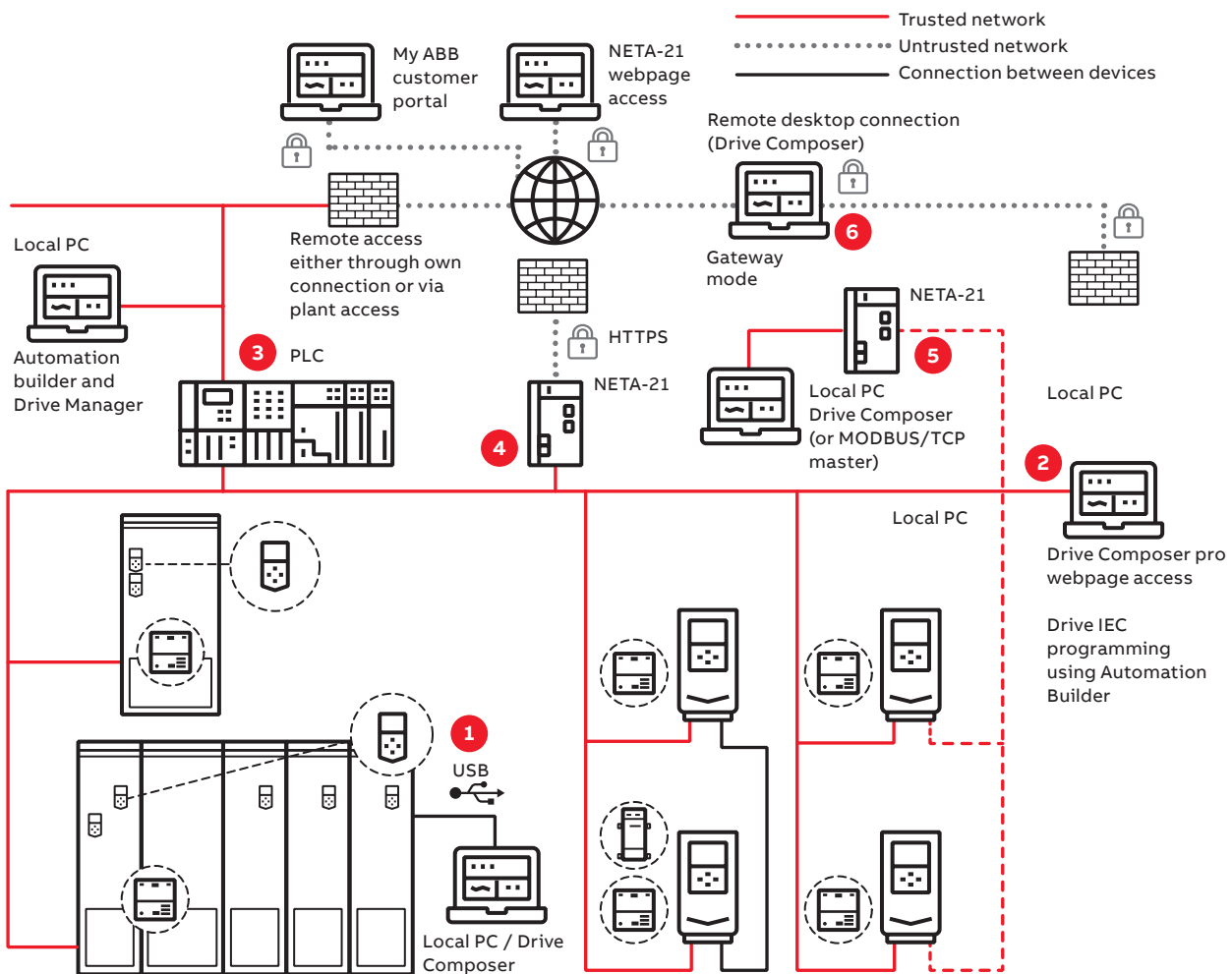

1. Local connections (point-to-point serial communication, e.g. USB) or
2. Shared (with control) upper-level physical fieldbus network (e.g., PROFINET) using Ethernet tool communication and/or
3. Communicating also through PLC system using Drive Manager device tool or
4. NETA-21 remote monitoring tool web interface or
5. NETA-21 acting as a gateway between or
6. Third-party remote desktop connection.

Connectivity to automation systems

—
01
ACS880 is compatible with many communication protocols
—
02
Input/output extension modules

Communication protocol adapters

ACS880 industrial drives are compatible with a wide range of communication protocols. The drive comes with a Modbus RTU fieldbus interface as standard.

The ACS880 supports two different communication connections simultaneously and offers the possibility for redundant communication. PROFIsafe (functional safety over PROFINET) is also supported.

Communication protocol adapters

Option code	Ordering code for loose item	Communication protocol	Adapter
+K451	68469341	DeviceNet™	FDNA-01
+K454	68469325	PROFIBUS DP, DPV0/DPV1	FPBA-01
+K457	68469376	CANopen®	FCAN-01
+K458	3AUA0000031336	Modbus RTU	FSCA-01
+K462	3AUA0000094512	ControlNet	FCNA-01
+K469	3AUA0000072069	EtherCAT®	FECA-01
+K470	3AXD5000019239	POWERLINK	FEPL-02
+K491	3AXD50000049964	Modbus/TCP	FMBT-21
+K492	3AXD50000192779	PROFINET IO	FPNO-21 ¹⁾
+K490	3AXD50000192786	EtherNet/IP	FEIP-21
+Q986	3AXD50000112821	PROFIsafe safety functions module	FSPS-21

¹⁾ For the PROFIsafe to work the PROFINET adapter module (FPNO-21) and the safety functions module FSO-12 (+Q973) or FSO-21 (+Q972) are required. The FPNO-21 adapter module enables PROFINET system redundancy S2 allowing the drive to establish connection with two control PLCs in a redundant manner.



—
01

—
02

Input/output extension modules

Standard input and output can be extended by using optional analog and digital input/output extension modules. The modules are easily installed in the extension slots located on the drive.

If there are not enough I/O extension slots in the drive, the FEA-03 module can increase the number of slots. The FEA-03 has two option slots for digital I/O extensions and speed feedback interface modules. The connection to the control unit is via an optical fiber link, and the adapter can be mounted on a DIN rail (35 × 7.5 mm).

Analog and digital input/output extension modules

Option code	Ordering code for loose item	Description	I/O module
+L501	68805368	4×DI/O, 2×RO	FIO-01
+L500	68805384	3×AI (mA/V), 1×AO (mA), 2×DI/O	FIO-11
+L515	3AUA0000108669	2×F-type option extension slots	FEA-03
+L525	3AUA0000141436	2×AI (mA/V), 2×AO (mA)	FAIO-01
+L526	3AUA0000141438	3×DI (up to 250 V DC or 230 V AC), 2×RO	FDIO-01

PROFINET S2 system redundancy for ABB drives

System redundancy is a high-priority requirement in process industry and infrastructure installations where the system must be operational even during component breakdowns and malfunctioning. The interruption of a continuous production process could potentially lead to large financial losses or safety hazards. Thanks to the new PROFINET S2 system redundancy of ABB drives, the unwanted downtime can be minimized. This leads to better process control with improved productivity.

PROFINET system redundancy S2 is now available for ABB drives with the optional PROFINET interface module FPNO-21. It allows the drive to establish connection with two control PLCs in a redundant manner.

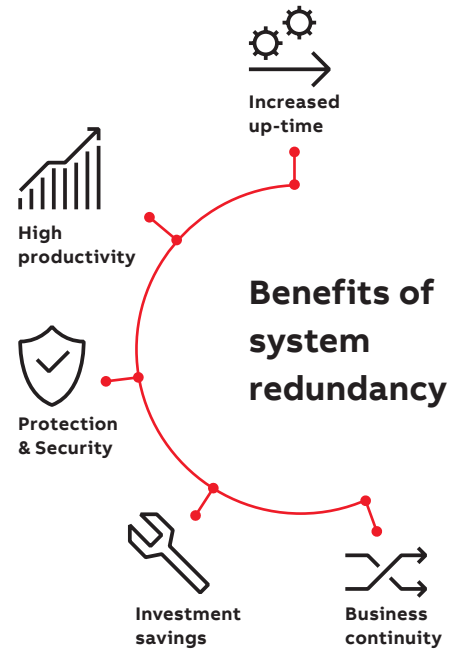

PROFINET IO
2 ports interface module.
Certified according to
Conformance Class B (CC-B)

SNTP Time synchronization



Ethernet tool network
PROFINET IO at the same time
with Drive Composer pro

PROFINET Shared Device
PROFIsafe support with FSO-12/-21
safety functions module

PROFINET S2 system redundancy

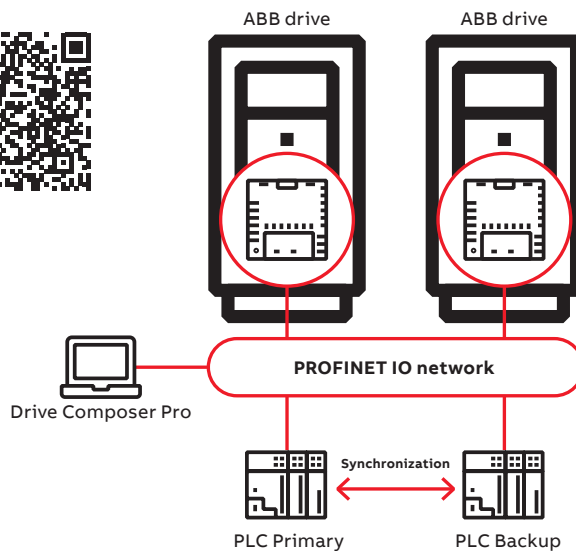

Feedback interface and DDCS communication options

—
01
FEN-01 TTL encoder
interface module
—
02
FDCO-01 DDCS
communication module

Speed feedback interfaces for precise process control

ACS880 drives can be connected to various feedback devices, such as HTL pulse encoders, TTL pulse encoders, absolute encoders and resolvers. The optional feedback module is installed in the option slot on the drive. It is possible to use two feedback modules at the same time, either of the same type or different types*).

*) Excluding FSE-31.



—
01

Feedback interface modules

Option code	Ordering code for loose item	Description	Feedback module
+L517	68805422	2 inputs (TTL pulse encoder), 1 output	FEN-01
+L518	68805830	2 inputs (SinCos absolute, TTL pulse encoder), 1 output	FEN-11
+L516	68805848	2 inputs (Resolver, TTL pulse encoder), 1 output	FEN-21
+L502	68978955	1 input (HTL pulse encoder), 1 output	FEN-31
+L521	3AXD5000023272	Pulse encoder interface for functional safety (for more details see section "Safety options")	FSE-31

DDCS communication option modules

The FDCO-0X optical DDCS communication options are add-on modules on the ACS880 industrial drives control unit. The modules include connectors for two fiber optic DDCS channels. The FDCO-0X modules make it possible to perform master-follower and AC800 M communication. Alternative way for drive to drive communication is to use the standard RS485 connection.



—
02

Optical communication modules

Option code	Ordering code for loose item	Description	Module
+L503	3AUA0000107392	Optical DDCS (10 Mbd/10 Mbd)	FDCO-01
+L508	3AUA0000107393	Optical DDCS (5 Mbd/10 Mbd)	FDCO-02

NETA-21

NETA-21 connects the drive to the cloud via the Internet or local Ethernet network.

The remote data helps you to base your decisions on solid facts and run your operations better and safer.

Remote monitoring helps you to recognize early signs of potential failures and react before a problem occurs. You can also remotely access the data from ABB drives to analyze and find the root cause of a problem.

With remote access you can analyze and optimize drive information anywhere, even in sites that are difficult to access, or when site visit is not possible.

- The module comes with a built-in web server and requires no Flash/Java plugins
- In the absence of a customer local area network, it can be connected via a mobile network router (either Ethernet or USB network adapter)
- One module can be connected to several drives at the same time

NETA-21 ^{*)}	Ordering code	Description
	3AUA0000094517	2 x panel bus interface max. 9 drives 2 x Ethernet interface SD memory card
	+K496	Connectivity for wired remote monitoring with NETA-21
	+K497	Connectivity for wireless remote monitoring with 4G modem and NETA-21

^{*)} Following options available for ACS880-07, -17 and -37

Customers can configure powertrains and customize the digital service plan

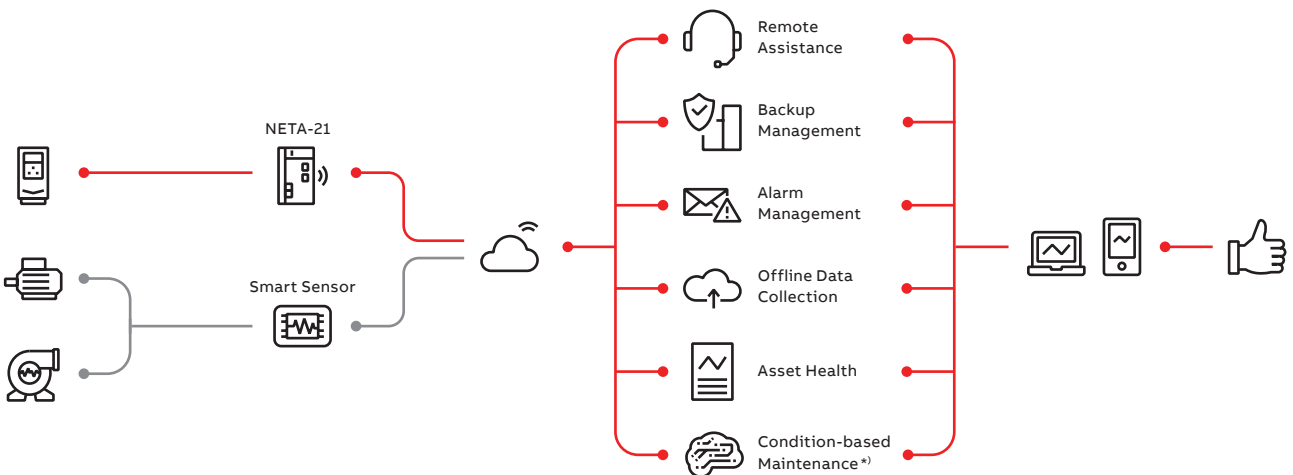

^{*)} Not available for all connectivity devices

Safety options

—
01
ACS880 drive with FSO-21, FSE-31 and FENA-21

Integrated safety

Integrated safety reduces the need for external safety components, simplifying configuration and reducing installation space. The safety functionality is a built-in feature of the ACS880, with safe torque off (STO) as standard. The STO function corresponds to an uncontrolled stop in accordance with stop category 0 of EN 60204-1. Additional safety functions can be commissioned with the optional and compact safety functions module. ACS880 drives offer functional safety with or without encoder. The drive's functional safety is designed in accordance with EN/IEC 61800-5-2 and complies with the requirements of the European Union Machinery Directive (2006/42/EC).

The safety functions are certified by TÜV Nord and comply with the highest performance requirements (SIL 3/PL e) in machinery safety.¹⁾

The safety functions module can also be ordered separately and installed afterwards to the drive.

PROFIsafe safety functions module, FSPS-21, with integrated PROFIsafe, and PROFINET IO connection supports STO and SS1-t safety functions. Since the functions are automatically configured, no additional safety settings are required in the drive.

Safety functions modules, FSO-12 and FSO-21, support a wide range of safety functions. Configuration of the functions is done with the Drive Composer pro PC tool, which provides an easy-to-use graphical user interface. Larger safety systems can be built using PROFIsafe over PROFINET connection between a safety PLC (such as AC500-S) and the ACS880 drive.

Safety function modules

Option code ²⁾	Ordering code for loose item	Description	Safety module
+Q973	3AXD50000016771	Safety functions module FSO-12	FSO-12
+Q972+L521	3AXD50000023987 + 3AXD50000023272	Safety functions module FSO-21 and encoder FSE-31	FSO-21+FSE-31
+Q971	—	ATEX-certified safe disconnection function, EX II (2) GD	
+Q982	—	PROFIsafe safety communication to be used together with FSO-12 or FSO-21: forces to select a functional safety module and PROFINET adapter, FPNO-21	FSO-12 or FSO-21 +FPNO-21
+Q986 ³⁾	3AXD50000112821	PROFIsafe safety functions module FSPS-21	FSPS-21
+L536	3AXD50000024934	Thermistor protection module FPTC-01	FPTC-01
+L537+Q971	3AXD50000024924	ATEX-certified thermistor protection module FPTC-02, Ex II (2) GD	FPTC-02

¹⁾ Thermistor modules comply with SIL 2 / PL c.

²⁾ Plus codes are valid for ACS880-01/11/31/04/04F and -14/34 frame R11.

³⁾ Please contact your local ABB office to check availability.



—
01

The connection is achieved by adding a PROFINET adapter, FPNO-21, to the drive.



Supported safety functions:

- Encoderless: SS1-t, SS1-r, SLS, SBC, SMS, SSE, POUS, STO
- With encoder (requires FSO-21 + FSE-31): SDI, SSM, SS1-t, SS1-r, SLS, SBC, SMS, SSE, POUS, STO

Pulse encoder interface module, FSE-31, provides safe encoder data to the safety functions module, and can simultaneously be used as a feedback device for the drive. FSE-31 requires an FSO-21 safety functions module and supports HTL encoders.

Thermistor protection modules, FPTC-01 and FPTC-02

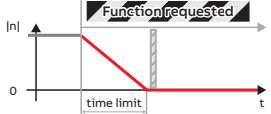
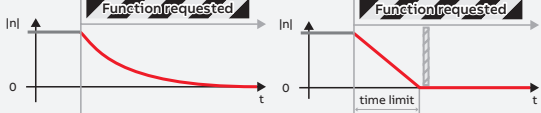
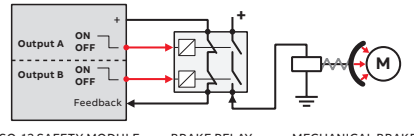
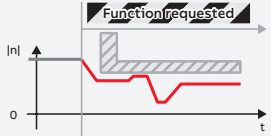
Safe temperature monitoring (STM) can be achieved by using FPTC thermistor protection modules.¹⁾

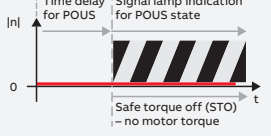
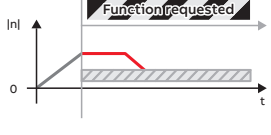
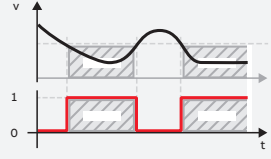
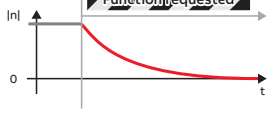
Safety function	Description	Supported functions			
		FSPS-21 (SS1-t)	FSO-12 without encoder (SS1-t) (SS1-r)	FSO-21 + FSE-31 + HTL encoder (SS1-t) (SS1-r)	
Safe stop 1 SS1-t SS1-r	Brings the machine to a stop using a monitored deceleration ramp. It is typically used in applications where the machinery motion needs to be brought to a stop (stop category 1) in a controlled way before switching over to the no-torque (STO) state	x	x	x	
Safe stop emergency SSE	Can be configured to, upon request, either activate STO instantly (category 0 stop), or first initiate motor deceleration and then, once the motor has stopped, activate the STO (category 1 stop).		x	x	
Safe brake control SBC	Provides a safe output for controlling the motor's external (mechanical) brakes, together with STO.		x	x	 FSO-12 SAFETY MODULE BRAKE RELAY MECHANICAL BRAKE
Safely-limited speed SLS	Ensures that the specified speed limit of the motor is not exceeded. This allows machine interaction to be performed at slow speed without stopping the drive. The safety function module comes with four individual SLS settings for speed monitoring.		x	x	
Safe maximum speed SMS	Monitors that the speed of the motor does not exceed the configured maximum speed limit.		x	x	
Prevention of unexpected start-up POUS	Ensures that the machine remains stopped when people are in the danger area.		x	x	
Safe direction SDI	Ensures that rotation is allowed only in the selected direction (available only with FSO-21 and FSE-31).			x	
Safe speed monitor SSM	Provides a safe output signal to indicate whether the motor speed is between user-defined limits (available only with FSO-21).			x	
Safe torque off STO	Brings the drive safely to a no-torque state, i.e. switches off the drive output to the motor, motor speed then coasts to a stop. ACS880 has safe torque off as standard.	x	x	x	

EMC – electromagnetic compatibility

Each ACS880 model can be equipped with a built-in filter to reduce high-frequency emissions.

What is EMC?

EMC stands for electromagnetic compatibility. It is the ability of electrical/electronic equipment to operate without problems in an electromagnetic environment.

Likewise, the equipment must not disturb or interfere with any other product or system in its locality. This is a legal requirement for all equipment taken into service within the European Economic Area (EEA).

Installation environments

A power drive system (PDS) can be connected to either industrial or public power distribution networks. The environment class depends on the way the PDS is connected to power supply.

The **1st environment** includes domestic premises. It also includes establishments directly connected without an intermediate transformer to a low voltage power supply network that supplies buildings used for domestic purposes.

The **2nd environment** includes all establishments directly connected to public low voltage power supply networks.

Immunity and emission compatibility

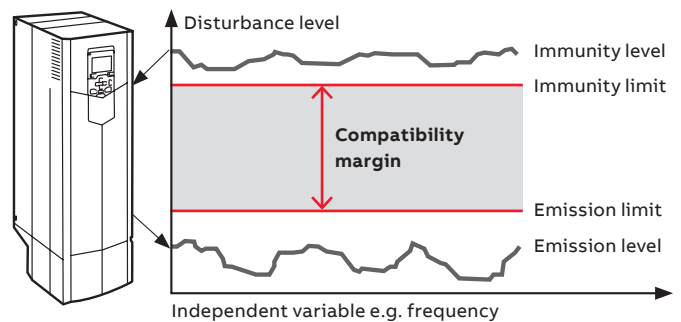

Installation environments

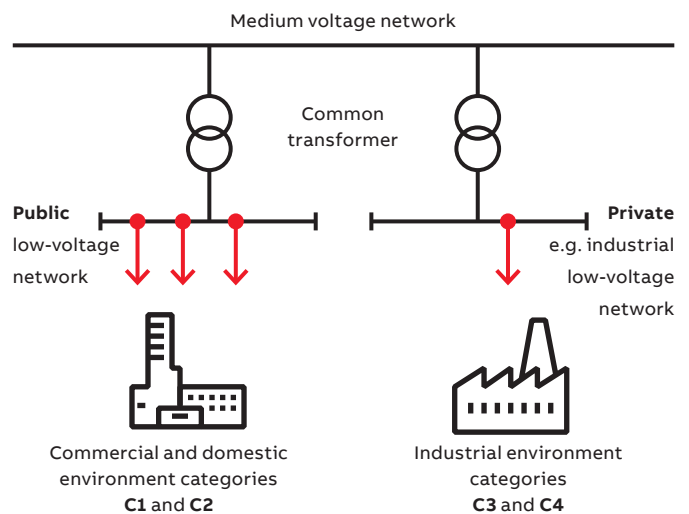

The product standard EN 61800-3 divides PDSs into four categories according to the intended use

C1 – 1st environment

- Household appliances
- Usually plug connectable to any wall outlet
- Anyone can connect these to the network
- Examples: washing machines, TV sets, computers, microwave ovens, etc.

C2 – 1st environment

- Fixed household and public appliances
- Need to be installed or operated by a professional
- Examples: elevators, rooftop fans, residential booster pumps, gates and barriers, supermarket freezers, etc.

C3 – 2nd environment

- Professional equipment
- Needs to be installed or operated by a professional
- In some rare cases, may also be pluggable
- Examples: any equipment for industrial usage only, such as conveyors, mixers, etc.

C4 – 2nd environment

- Professional equipment
- Needs to be fixed installation and operated by a professional
- Examples: paper machines, rolling mills, etc.

Comparison of EMC standards

EN 61800-3, product standard	EN 61800-3, product standard	EN 55011, product family standard for industrial, scientific and medical (ISM) equipment	EN 61000-6-4, generic emission standard for industrial environments	EN 61000-6-3, generic emission standard for residential, commercial and light-industrial environments
Category C1	1 st environment, unrestricted distribution	Group 1. Class B	Not applicable	Applicable
Category C2	1 st environment, restricted distribution	Group 1. Class A	Applicable	Not applicable
Category C3	2 nd environment, unrestricted distribution	Group 2. Class A	Not applicable	Not applicable
Category C4	2 nd environment, restricted distribution	Not applicable	Not applicable	Not applicable

Selecting an EMC filter

Drive type	Voltage (V)	Frame sizes	1 st environment, restricted distribution, C2, grounded network (TN) Option code	2 nd environment, C3, grounded network (TN) Option code	2 nd environment, C3, ungrounded network (IT) Option code	2 nd environment, C4, grounded network (TN) ⁴⁾
ACS880-01	208 to 240		R1 to R8	+E202	+E200	–
ACS880-01	380 to 500	R1 to R9	+E202	+E200	+E201 ¹⁾	As standard
ACS880-01	525 to 690	R3 to R9	–	+E200	+E201 ¹⁾	As standard
ACS880-04	380 to 500	R10, R11	+E202	+E200	+E201	As standard
ACS880-04	525 to 690	R10, R11	–	+E200	+E201	As standard
ACS880-04	380 to 690	nxD8T+ n×R8i	Not for 690 V. Only for 1×D8T ²⁾	As standard ³⁾	As standard ³⁾	As standard
ACS880-04F	380 to 690	R11	–	+E200	+E201	As standard
ACS880-04XT	380 to 500	2×R10/11	ARFI-10	+E200	+E201	As standard
ACS880-04XT	525 to 690	2×R10/11	–	+E200	+E201	As standard
ACS880-04FXT	380 to 500	n×R11	ARFI-10	+E200	+E201	As standard
ACS880-04FXT	525 to 690	n×R11	–	+E200	+E201	As standard
ACS880-11	380 to 500	R3 to R8	+E202 (not available for R6)	+E200	+E201	As standard
ACS880-31	380 to 500	R3 to R8	+E202 (not available for R6)	+E200	+E201	As standard
ACS880-14	380 to 690	R11	+E202	+E200	–	As standard
ACS880-14	380 to 690	2×R8i	Not for 690 V. Only for 1×R8i ²⁾	As standard ³⁾	As standard ³⁾	As standard
ACS880-34	380 to 690	R11	+E202	+E200	–	As standard
ACS880-34	380 to 690	2×R8i	Not for 690 V. Only for 1×R8i ²⁾	As standard ³⁾	As standard ³⁾	As standard
ACS880-104	380 to 690	R1 to n×R8i	–	As standard ³⁾	As standard ³⁾	As standard
ACS880-204	380 to 690	R1i to R4i, R6i, n×R8i	Not for 690 V. Only for sizes up to 1×R8i ²⁾	As standard ³⁾	As standard ³⁾	As standard
ACS880-304	380 to 690	D×D, n×DXT	Not for 690 V. Only for 1×D8T ²⁾	As standard ³⁾	As standard ³⁾	As standard
ACS880-104LC	525 to 690	n×R8i	–	As standard ³⁾	As standard ³⁾	As standard
ACS880-904	380 to 690	n×R8i	–	As standard ³⁾	As standard ³⁾	As standard
ACS880-204LC	525 to 690	n×R8i	–	As standard ³⁾	As standard ³⁾	As standard
ACS880-304LC	525 to 690	nxD8D, nxD8T	–	As standard ³⁾	As standard ³⁾	As standard

¹⁾ 2nd environment, C4: ACS880-01, 380 to 500 V, frame sizes R1 to R5. ACS880-01, 690 V, frame sizes R3 to R6.

²⁾ For Category C2 optional equipment is needed, and the drive must be installed according to the instructions given in the manuals.

³⁾ For Category C3 no optional equipment is needed, but the drive must be installed according to the instructions given in the manuals.

⁴⁾ For Category C4 no optional equipment is needed, but the drive must be installed according to the instructions given in the manuals. EMC plan required.

По вопросам продаж и поддержки обращайтесь:

Алматы (7273)495-231
Ангарск (3955)60-70-56
Архангельск (8182)63-90-72
Астрахань (8512)99-46-04
Барнаул (3852)73-04-60
Белгород (4722)40-23-64
Благовещенск (4162)22-76-07
Брянск (4832)59-03-52
Владивосток (423)249-28-31
Владикавказ (8672)28-90-48
Владимир (4922)49-43-18
Волгоград (844)278-03-48
Вологда (8172)26-41-59
Воронеж (473)204-51-73
Екатеринбург (343)384-55-89
Иваново (4932)77-34-06
Ижевск (3412)26-03-58
Иркутск (395)279-98-46
Казань (843)206-01-48

Калининград (4012)72-03-81
Калуга (4842)92-23-67
Кемерово (3842)65-04-62
Киров (8332)68-02-04
Коломна (4966)23-41-49
Кострома (4942)77-07-48
Краснодар (861)203-40-90
Красноярск (391)204-63-61
Курган (3522)50-90-47
Курск (4712)77-13-04
Липецк (4742)52-20-81
Магнитогорск (3519)55-03-13
Москва (495)268-04-70
Мурманск (8152)59-64-93
Набережные Челны (8552)20-53-41
Нижний Новгород (831)429-08-12
Новокузнецк (3843)20-46-81
Новосибирск (383)227-86-73
Ноябрьск(3496)41-32-12

Омск (3812)21-46-40
Орел (4862)44-53-42
Оренбург (3532)37-68-04
Пенза (8412)22-31-16
Пермь (342)205-81-47
Петрозаводск (8142)55-98-37
Псков (8112)59-10-37
Ростов-на-Дону (863)308-18-15
Рязань (4912)46-61-64
Самара (846)206-03-16
Санкт-Петербург (812)309-46-40
Саранск (8342)22-96-24
Саратов (845)249-38-78
Севастополь (8692)22-31-93
Симферополь (3652)67-13-56
Смоленск (4812)29-41-54
Сочи (862)225-72-31
Ставрополь (8652)20-65-13
Сургут (3462)77-98-35

Сыктывкар (8212)25-95-17
Тамбов (4752)50-40-97
Тверь (4822)63-31-35
Тольятти (8482)63-91-07
Томск (3822)98-41-53
Тула (4872)33-79-87
Тюмень (3452)66-21-18
Улан-Удэ (3012)59-97-51
Ульяновск (8422)24-23-59
Уфа (347)229-48-12
Хабаровск (4212)92-98-04
Чебоксары (8352)28-53-07
Челябинск (351)202-03-61
Череповец (8202)49-02-64
Чита (3022)38-34-83
Якутск (4112)23-90-97
Ярославль (4852)69-52-93

Россия +7(495)268-04-70

Казахстан +7(7172)727-132

Киргизия +996(312)96-26-47

<https://abbd rives.nt-rt.ru/> || aei@nt-rt.ru