

По вопросам продаж и поддержки обращайтесь:

Алматы (7273)495-231
Ангарск (3955)60-70-56
Архангельск (8182)63-90-72
Астрахань (8512)99-46-04
Барнаул (3852)73-04-60
Белгород (4722)40-23-64
Благовещенск (4162)22-76-07
Брянск (4832)59-03-52
Владивосток (423)249-28-31
Владикавказ (8672)28-90-48
Владимир (4922)49-43-18
Волгоград (844)278-03-48
Вологда (8172)26-41-59
Воронеж (473)204-51-73
Екатеринбург (343)384-55-89
Иваново (4932)77-34-06
Ижевск (3412)26-03-58
Иркутск (395)279-98-46
Казань (843)206-01-48

Калининград (4012)72-03-81
Калуга (4842)92-23-67
Кемерово (3842)65-04-62
Киров (8332)68-02-04
Коломна (4966)23-41-49
Кострома (4942)77-07-48
Краснодар (861)203-40-90
Красноярск (391)204-63-61
Курган (3522)50-90-47
Курск (4712)77-13-04
Липецк (4742)52-20-81
Магнитогорск (3519)55-03-13
Москва (495)268-04-70
Мурманск (8152)59-64-93
Набережные Челны (8552)20-53-41
Нижний Новгород (831)429-08-12
Новокузнецк (3843)20-46-81
Новосибирск (383)227-86-73
Ноябрьск (3496)41-32-12

Омск (3812)21-46-40
Орел (4862)44-53-42
Оренбург (3532)37-68-04
Пенза (8412)22-31-16
Пермь (342)205-81-47
Петрозаводск (8142)55-98-37
Псков (8112)59-10-37
Ростов-на-Дону (863)308-18-15
Рязань (4912)46-61-64
Самара (846)206-03-16
Санкт-Петербург (812)309-46-40
Саранск (8342)22-96-24
Саратов (845)249-38-78
Севастополь (8692)22-31-93
Симферополь (3652)67-13-56
Смоленск (4812)29-41-54
Сочи (862)225-72-31
Ставрополь (8652)20-65-13
Сургут (3462)77-98-35

Сыктывкар (8212)25-95-17
Тамбов (4752)50-40-97
Тверь (4822)63-31-35
Тольятти (8482)63-91-07
Томск (3822)98-41-53
Тула (4872)33-79-87
Тюмень (3452)66-21-18
Улан-Удэ (3012)59-97-51
Ульяновск (8422)24-23-59
Уфа (347)229-48-12
Хабаровск (4212)92-98-04
Чебоксары (8352)28-53-07
Челябинск (351)202-03-61
Череповец (8202)49-02-64
Чита (3022)38-34-83
Якутск (4112)23-90-97
Ярославль (4852)69-52-93

Россия +7(495)268-04-70

Казахстан +7(7172)727-132

Киргизия +996(312)96-26-47

<https://abbdrives.nt-rt.ru/> || aei@nt-rt.ru

ПРОМЫШЛЕННЫЕ ПРИВОДЫ

Техническое описание на

блоки

ACS880-1007LC



The all-compatible ACS880 series

Uncompromized productivity

The ACS880 is an all-compatible ABB industrial drive, offered in a range of wall-mounted drives, drive modules and cabinet-built drives.

ABB's all-compatible drives are designed to provide customers across industries and applications with unprecedented levels of compatibility and flexibility. Our cabinet-built ACS880 multidrives are customized to meet the particular needs of specific industries, such as metals, pulp and paper, oil and gas, mining, harbours, offshore, marine, automotive and power plants. They can control a wide range of applications, including paper machines, winders, rolling mills, processing lines, roller tables, cranes, test benches and drilling.

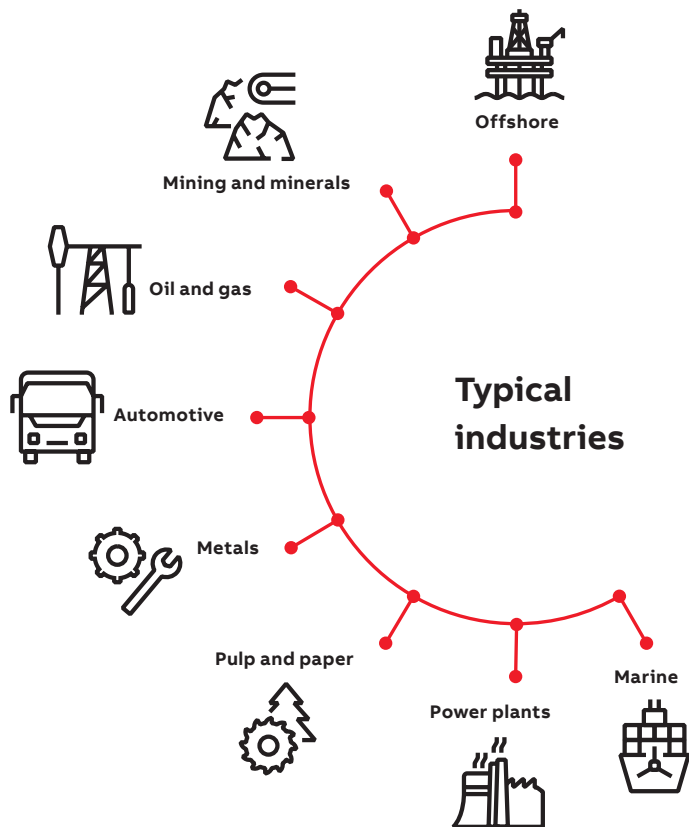

High quality

Reliability and consistent high quality

ACS880 drives are designed for customers who value high quality and robustness in their applications. They have features such as coated boards, making the ACS880 suitable for harsh conditions. Additionally, every ACS880 drive is factory-tested at full load to ensure maximum reliability. The tests include performance and all protective functions.

High performance, safety and configurability

The ACS880 offers the highest level of performance. The drives are equipped with ABB's signature direct torque control (DTC), which provides precise speed and torque control for all applications and supports virtually any type of motor.

Extensive ACS880 offering includes wall-mounted drives, drive modules and cabinet-built drives, as well as low harmonic and regenerative variants.

The ACS880 has all the essential features built-in reducing the time required for engineering, installation and commissioning. A wide range of options are also available to optimize the drive for different requirements, including certified, integrated safety features.

Simplify your world without limiting your possibilities

Built-to-order to meet customers' needs, the ACS880 multidrives can meet technical challenges through a wide selection of options that are all mountable within the cabinet.

Easy to use

- All-compatible drives share the same easy-to-use user interface
- Multilingual control panel with clear display
- Graphical PC tools for engineering, commissioning and maintenance

See page 08



Up to IP54

Built to order for simplified installation

- All the essential features built-in
- Flexible product configurations engineered to order
- Wide selection of options and variants
- Compact design
- Enclosure classes for different environments
- Extensive selection of support material and tools for engineering

See page 10



Fieldbus and Industrial Ethernet solutions

- Communication with all major automation networks
- Remote monitoring
- Integration tools for various PLCs

See page 12



Nine-year maintenance interval

Minimized downtime

- Robust, long lifetime design for maximum reliability
- Coated circuit boards for harsh conditions
- Removable memory unit
- Each drive factory-tested at full load
- Nine-year maintenance interval
- Worldwide service and support
- Advanced features for analyzing and resolving issues

See page 13



A single supply and DC bus arrangement with multiple inverters reduce line power, cabinet size and investment costs.



Ensure the safety of your machinery and processes with drive-based functional safety

- Safe torque off built-in as standard
- Optional safety modules for extended safety functions
- Encoderless safe speed detection
- Highest level of machinery safety, SIL 3 / PL e
- TÜV certified

See page 14



Global compatibility with various demands

- Global product approvals, e.g. CE, UL, cUL, CSA, marine certifications, ATEX
- Support for various motor types
- Low harmonic content
- Possibility for regeneration

See page 15



Premium control and programmability

- Direct torque control (DTC) for precise control
- Speed, torque and position control as well as synchronizing
- Adaptive programming as standard
- Drive-based PLC programmability (IEC 61131-3) for fully customized solutions

See page 16

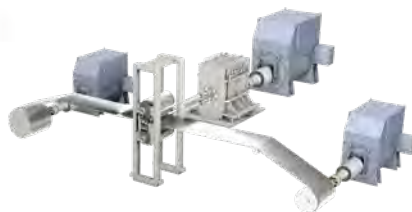

Application- and industry specific solutions

- Ready-made optimized solutions for various applications and industries

See pages 18 - 19

Engineered to order for simplified installation

Compact tailor made design

ACS880 Multidrives offer a wide selection of pre-defined options, which include the typical requirements of different industries.

Our ACS880 Multidrives are always engineered-to-order products. This ensures that the customer's and application's demands are taken as basis of our design and even complex requirements can be included to create a unique solution. Our dedicated team takes care of your needs to ensure the maximum performance, uptime and quality in daily processes.

All ACS880 drives have a choke for harmonic filtering, a Modbus RTU fieldbus interface, and safe torque off functionality as standard. Other built-in features, standard or optional, include EMC filters, brake options, low harmonic and regenerative functionality and various I/O extensions, communication protocol adapters, and functional safety modules. To further simplify the installation, ACS880 multidrives have fast connectors for motor cables.

Multidrive design is extremely compact:

- High packing density with 16 inverter units up to frame size R2i can be installed into one cabinet
- Reliable diode bridge with high power density
- Highly efficient thermal handling as heat loss of each inverter unit is guided to the back of the cabinet. All cabinets are their own compartments.

Enclosures for different environments

ACS880 offering includes complete and compact solutions for dusty and wet environments with up to IP54 enclosure class.

All essential features built-in

Engineering support

ABB provides an extensive selection of support material and tools to help in engineering, such as:

- Dimensioning tools, e.g. DriveSize
- Safety circuit design tools
- Configuration tool
- Electrical drawings
- Application guides
- User manuals

These tools and support from our experts ensure that the drive system can be set up easily and reliably.

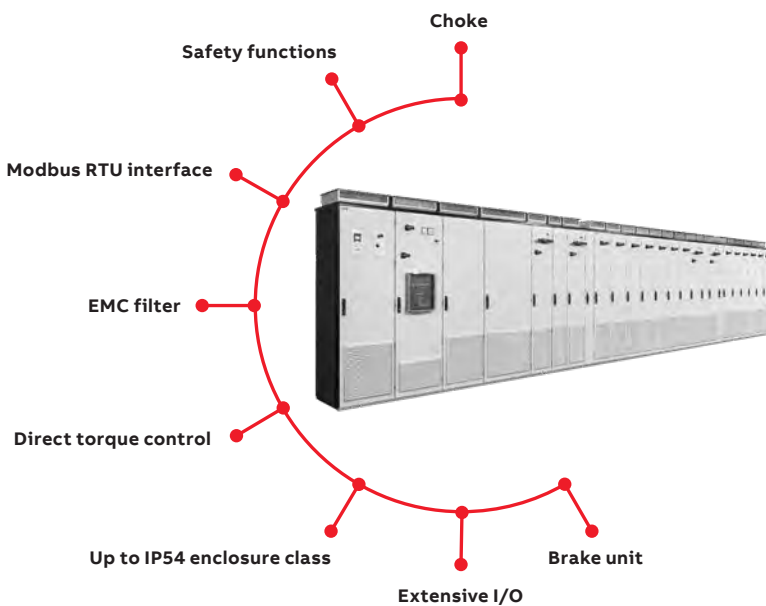

DriveSize dimensioning tool for selecting the optimal drive

DriveSize is designed to help select the optimal drive, motor and transformer for the application. Based on data supplied by the user, the tool calculates and suggests which drive and motors to use.

DriveSize is a free software and can be used either online or downloaded for

Fieldbus and Industrial Ethernet solutions

Easy, secure, and reliable integration with all automation ecosystems

Smooth data communication is central to running critical infrastructure, transportation, and industrial networks of all kinds. ABB is a technology leader in digital automation communication networks. We provide device integration, wireless and wired products, and systems that help you to make the Industrial Internet of Things a reality. ACS880 drives support all major fieldbus protocols, giving you the flexibility, compatibility, and security. As the standard, the drives come with Modbus RTU fieldbus interface module and drive-to-drive communication link.

The drives support advanced communication features:

- Accurate torque and speed control over the PROFINET or PROFIBUS
- Increased control system availability with the PROFINET S2 redundancy
- PROFIsafe over PROFINET
- Support for multiple protocols simultaneously
- Shared Ethernet connection for automation communication and Drive Composer pro PC tool – all communication via the same cable

To minimize connectivity-related risks, cybersecurity is a built-in, integral part of the ACS880.

To simplify ACS880's connectivity to automation systems, ABB offers support tools for seamless integration with PLCs from ABB and several other manufacturers.

Remote monitoring

With a built-in web server and standalone data logger, the NETA-21 remote monitoring tool enables secure worldwide access to your drives.



Better connectivity and user experience

Fieldbus and Industrial Ethernet solutions

Easy, secure, and reliable integration with all automation ecosystems

Smooth data communication is central to running critical infrastructure, transportation, and industrial networks of all kinds. ABB is a technology leader in digital automation communication networks. We provide device integration, wireless and wired products, and systems that help you to make the Industrial Internet of Things a reality. ACS880 drives support all major fieldbus protocols, giving you the flexibility, compatibility, and security. As the standard, the drives come with Modbus RTU fieldbus interface module and drive-to-drive communication link.

The drives support advanced communication features:

- Accurate torque and speed control over the PROFINET or PROFIBUS
- Increased control system availability with the PROFINET S2 redundancy
- PROFIsafe over PROFINET
- Support for multiple protocols simultaneously
- Shared Ethernet connection for automation communication and Drive Composer pro PC tool – all communication via the same cable

To minimize connectivity-related risks, cybersecurity is a built-in, integral part of the ACS880.

To simplify ACS880's connectivity to automation systems, ABB offers support tools for seamless integration with PLCs from ABB and several other manufacturers.

Remote monitoring

With a built-in web server and standalone data logger, the NETA-21 remote monitoring tool enables secure worldwide access to your drives.



Better connectivity and user experience

Premium control and programmability

Direct torque control (DTC)

ABB's state of the art motor control technology provides precise speed and torque control, with or without an encoder, even close to zero speed. DTC provides reliable starts and rapid reactions to load or network changes, and ensures smooth and continuous operation. DTC provides optimal control, even with sine filters.

The energy optimizer feature maximizes motor efficiency by ensuring maximum torque per ampere, reducing the power drawn from the supply.

Position control and synchronizing

Position control allows to meet motion systems demands without the need of an external position controller. The ready-made motion functions can be easily configured by parameters.

For optimized solution for your application, the functions can be modified and extended by IEC 61131 programming using PLCopen motion blocks.

Additional features, such as built-in synchronized drive to drive link and possibility for encoderless positioning, make ACS880 position control ideal for any axis.

Drive programming

To meet your specific application needs, you can customize your ACS880 with an extensive range of user-definable software settings (parameters) and adaptive programming. This makes fine-tuning the ready-made application control program functionalities easy. For further customization, drive application programming based on IEC 61131 standard is available for full PLC programmability. IEC programming uses the same programming environment as ABB PLCs. It is also easy to integrate the ACS880 with other components, such as PLCs and HMIs.

Adaptive programming

is an easy to use dynamic programming which allows flexible adjustments to the ACS880 software.

IEC programming

based on IEC 61131 standard for full scale PLC programmability is available as an option.

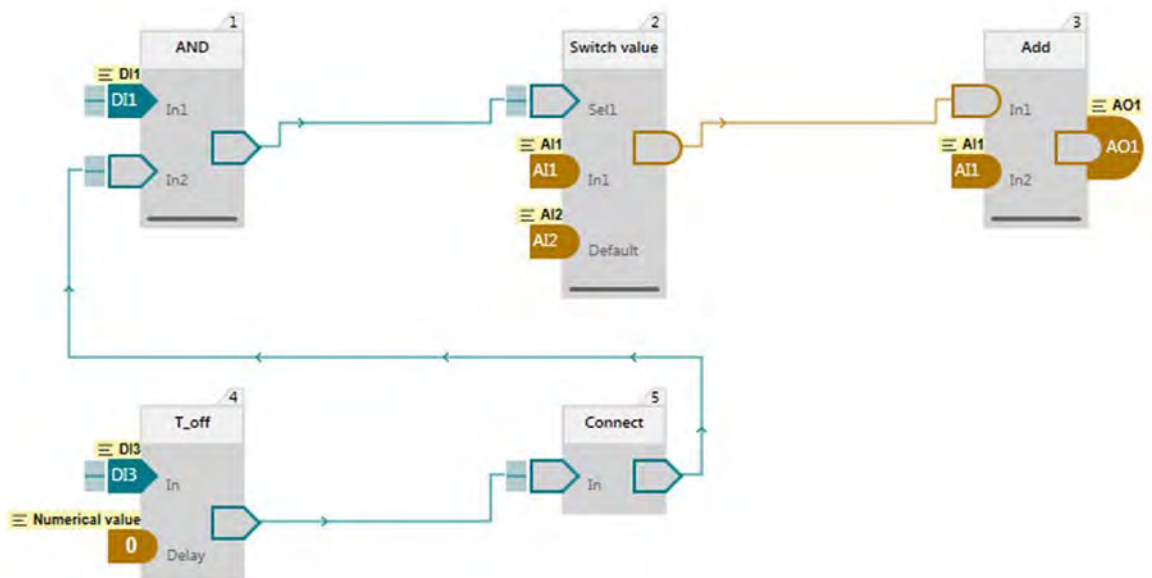

Application- and industry-specific solutions

Cranes (EOT cranes), +N5050

- Mechanical brake control
- Slow down and end limit logic
- Antisway
- Hoist speed optimization
- Shaft synchro

Winches, +N5100

- Mooring
- Anchor control
- Accurate open loop speed & torque control
- Winch interface for multiple control stands

Winders, +N5000

- Roll diameter calculation
- Tension control
- Dancer and load cell control
- Inertia and friction compensation

Artificial oil lifting, PCP +N5200

- Backspin control
- Automatic pump speed control
- Induction and PM motor control
- Protections for pump mechanics

Optimal grid control, +N8053

- Creation of an island AC grid
- Support the operation of a distributed power system



By working closely with customers over many years, ABB has developed application control programs and software features for specific applications and industries. This results in programs and features that include lessons learned from many customers, and that are designed to give you the flexibility to adapt the programs to your specific needs.

Advantages:

- Enhanced application usability
- Lower energy consumption
- Increased safety
- Reduced need for PLCs
- Protected machinery
- Optimized application productivity
- Optimized time usage and lower operational costs



LV synchronous machine, +N8052

- Machine model based flux and torque control
- Machine saturation model
- Excitation current reference calculation
- Autophasing function

Test bench, +N5300

- Fast communication
- High torque accuracy and linearity
- Acceleration damping
- Minimized motor noise

High speed test bench, +P967

- High-speed test benches up to 25 000 rpm
- For air-cooled inverter units -107 (INU) R8i frames

Chemical industry

- Direct torque control with sine filters
- Nine-year service interval
- Functionality that conforms with NAMUR requirements

Explosive atmospheres

- Type approval with ABB Ex motors
- ATEX-approved safe torque off, STO (+Q971) and thermistor protection module (+L537)

Marine

- Type approval from various key classification bodies (+C132)
- Optimal grid control for shore-to-ship and hotel load applications
- Product certification process (+C20X)

Hydrogen production

- DC supply for electrolysis
- Optional DC/DC-converter for superior DC voltage

Technical data

Mains connection	
Voltage and power range	3-phase, U_{N3} 380 to 415 V, +10%/-10% 3-phase, U_{N5} 380 to 500 V, +10%/-10% 3-phase, U_{N7} 525 to 690 V, +10%/-10% Inverter unit (INU) 1.5 to 6000 kW Diode supply unit (DSU) 50 to 5500 kVA IGBT supply unit (ISU) 300 to 6944 kVA Regenerative rectifier unit (RRU) 400 to 6100 kVA
Frequency	50/60 Hz $\pm 5\%$
Power factor	IGBT supply unit (ISU): - $\cos\phi = 1$ (fundamental) - $\cos\phi = 0.99$ (total) Diode supply unit (DSU) and regenerative rectifier unit (RRU): - $\cos\phi = 0.98$ (fundamental) - $\cos\phi = 0.93$ to 0.95 (total)
Efficiency (at nominal power)	98% with DSU and RRU 97.5% with ISU
Motor connection	
Voltage	3-phase output voltage 0 to $U_{N3} / U_{N5} / U_{N7}$
Frequency	0 to ± 598 Hz ^{1) 3)}
Motor control	Direct torque control (DTC)
Torque control	Torque step rise time: Open loop - 5 ms with nominal torque Closed loop - 5 ms with nominal torque Non-linearity: Open loop - \pm % with nominal torque Closed loop - \pm % with nominal torque
Speed control	Static accuracy: Open loop - 0% of motor slip Closed loop - .01% of nominal speed Dynamic accuracy: Open loop - .3 to 0.4% seconds with 100% torque step Closed loop - .1 to 0.2% seconds with 100% torque step
Product compliance	
CE, UKCA Low Voltage Directive 2014/35/EU according to EN 61800-5-1:2007+A1:2017+A11:2021 SGS statement according to IEC 61800-5-1 Machinery Directive 2006/42/EC EMC Directive 2014/30/EU ATEX Directive 2014/34/EU, EN 50495 Quality assurance system ISO 9001 and Environmental system ISO 14001 RoHS 2011/65/EU and Delegated Directive (EU) 2015/836 cULus listed according to UL 508A and CSA C22.2 No. 14, CSA certified according to CSA C22.2 No. 14 ⁸⁾ RCM, EAC ²⁾ TÜV Nord certification for functional safety ⁵⁾ ATEX-certified safe disconnection function and thermistor & PT100 protection functions, Ex II (2) GD ⁶⁾ UKEX Type Examination certificates for safe disconnection function and thermistor and PT100 protection functions, Ex II (2) GD 6) Marine type approvals: ABS, BV, CCS, ClassNK, DNV GL, KR, LR, RINA For product specific availability, drives/segments/marine/marine-type-approvals	
EMC according to EN 61800-3: 2004 + A1: 2012. See page 61.	
1 st environment, restricted distribution category C2, as option 1000 A and up to 500 V 2 nd environment, unrestricted distribution category C3, as option	
Built-in functional safety. See pages 58 - 59.	
For safe torque off (STO) and safety functions modules	EN/IEC 61800-5-2, IEC 61508: SIL 3, IEC 61511: SIL 3, EN/IEC 62061: SIL CL 3, EN ISO 13849-1: PL e – TÜV Nord certified ⁵⁾
Safety over fieldbus	PROFIsafe over PROFINET, certified.

Environmental limits	
Ambient temperature	
Transport	-40 to +70 °C
Storage	-40 to +70 °C
Operation area (air-cooled)	0 to +40 °C, no frost allowed +40 to 50 °C with derating of 1%/1 °C
(liquid-cooled)	0 to +45 °C, no frost allowed +45 to +55 °C with derating of 0.5%/1 °C
Cooling method	
Air-cooled	Dry clean air
Liquid-cooled	Direct liquid-cooling, coolant Antifrogen® L Incoming coolant temperature to module (-x07LC): - 0 to +40 °C as standard - 40 to +45 °C with derating of 2%/1 °C - 45 to +50 °C with derating of 2%/1 °C or 6%/1 °C ⁷⁾ Incoming coolant temperature to optional liquid-cooling unit (-1007LC) (fresh water or sea water): - 0 to +36 °C as standard - 36 to +46 °C with derating of 2%/1 °C
Altitude	
0 to 1,000 m	Without derating
1,000 to 4,000 m	With derating of 1% / 100 m ⁴⁾
Relative humidity	5 to 95%, no condensation allowed
Degree of protection	
Air-cooled	IP22 as standard (IP20 cabinet doors open) IP42 or IP54 as option
Liquid-cooled	IP42 as standard (IP20 cabinet doors open) IP54 as option
Paint color	RAL 9017, RAL 7035
Pollution degree	PD 2
Contamination levels	No conductive dust allowed
Storage	IEC 60721-3-1:1997, Class 1C2 (chemical gases), Class 1S2 (solid particles) ^{*)}
Operation	IEC 60721-3-3:2002, Class 3C2 (chemical gases), Class 3S2 (solid particles) ^{*)}
Transportation	IEC 60721-3-2:1997, Class 2C2 (chemical gases), Class 2S2 (solid particles) ^{*)}
Vibration	IEC 60068-2-6, 10 to 57 Hz 0.075 mm displacement amplitude 57 to 150 Hz 1 g Units with marine construction: - ax. 1 mm (peak value 2 to 13.2 Hz) - ax. 0.7 g (13.2 to 100 Hz) sinusoidal

^{*)} C = Chemically active substances

^{*)} S = Mechanically active substances

¹⁾ Operation above 120 Hz might require type specific derating, please contact your local ABB office

²⁾ EAC has replaced GOST R

³⁾ For higher operational output frequencies please contact your local ABB office

⁴⁾ Derating reduced by lower than 40 °C ambient temperature

⁵⁾ For available certificates, see

Thermistor protection function (+L537+Q971)

⁶⁾ PTC/PT100 thermal motor protection (+L513/L514+Q971)

⁷⁾ See product specific hardware manual for detailed derating rules.

⁸⁾ UL/CSA panel shop standards that ACS880 multidrives complies with, only allow ambient temperature of 0...40C.

ACS880 multidrives

—
01
Multidrive configuration with supply unit, DC bus and multiple inverters
—
02
Multidrives are constructed for controlling multiple motors. The most important units are: drive units (known as inverter units (INU)) and supply units (DSU/RRU/ISU).

The multidrives principle is based on a common DC bus arrangement, enabling single power entry and common braking resources for several drives. There are several possibilities on the supply side starting from a simple diode supply unit up to highly sophisticated active IGBT supply units.

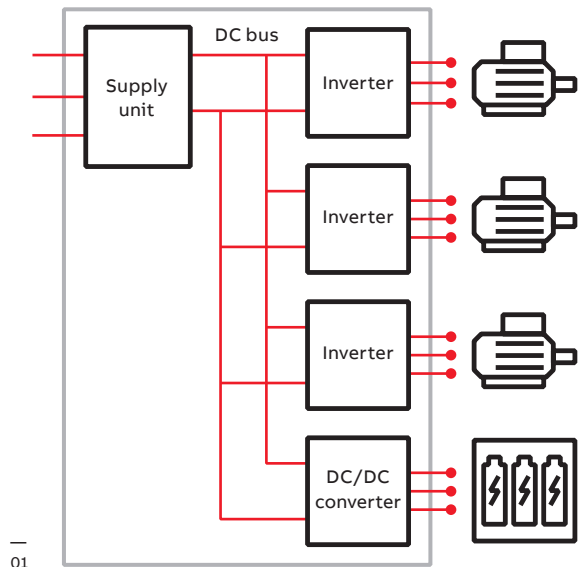

—
02

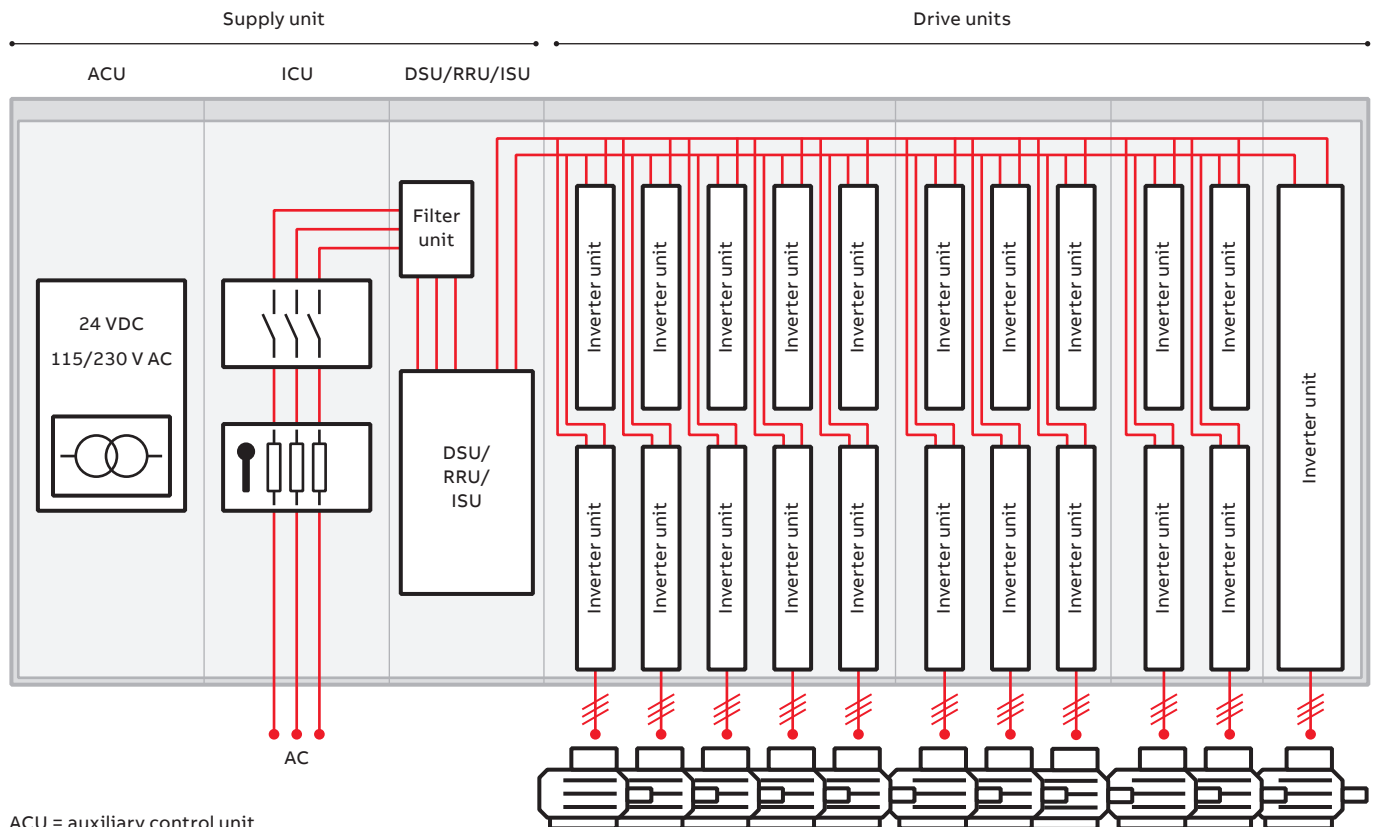

ACU = auxiliary control unit
ICU = incoming unit
DSU = diode supply unit
RRU = regenerative rectifier unit
ISU = IGBT supply unit



Multidrive can be used wherever several motors form part of a single process. With a compact module design and high power density, the single supply and DC bus arrangement with multiple inverters provides many advantages:

- Savings in cabling, installation and maintenance costs
- Reduced component count and footprint, as well as increased reliability
- Energy and cost savings. As the energy circulates over the common DC bus, all energy is not taken from the supply network. Energy circulation can also be used for motor-to-motor braking without the need for a braking chopper or regenerative supply unit.
- Reduced line power and currents allowing the supply unit to have smaller dimensions.
- The common supply of the multidrives enables the implementation of overall safety and control functions.

In multimotor applications, for example in a paper machine, the individual inverter modules provide fast communication of torque and speed signals between the inverters for controlling the tension in the paper web. Also in cases where the shafts of the individual motors are not tightly coupled, for example in sugar centrifuges, each inverter module can be programmed with a speed profile in order to minimize overall energy consumption. These two examples merely demonstrate the range of applications where multidrives offer substantial benefits over other types of drive constructions. High power units D7T, D8T, R6i, R7i and nxR8i have speed controlled cooling fans as a standard.

Ratings, types and voltages

Liquid cooling unit, ACS880-1007LC

Range 380 to 690 V

Liquid-cooling unit type	Nominal ratings			Noise level (dB(A))	Losses				Internal flow ¹⁾ (l/min)	External flow ²⁾ (l/min)
	P_{\max} (kW)	Internal coolant volume (l)	External coolant volume (l)		$P_{\text{loss total}}$ (kW)	$P_{\text{loss coolant}}$ (kW)	$P_{\text{loss air}}$ (kW)	P_{drop} (kPa)		
ACS880-1007LC-0070 ³⁾	70	17	3	55	0.4	0.3	0.1	150	81/107	120
ACS880-1007LC-0195+C140 ³⁾ /C141 ⁴⁾	195	31/35	8	55	1.3	1.0	0.3	150	270/355	467
ACS880-1007LC-0195+C213 ⁵⁾	195	35	8	57	2.1	1.8	0.3	150	310/415	467

¹⁾ 120 kPa, Antifrogen® L 25%, 40 °C, 50/60 Hz

²⁾ 36 °C water

³⁾ Single pump

⁴⁾ Redundant, one pump running at a time

⁵⁾ Redundant, two pumps running at a time

Nominal ratings

P_{\max}	Maximum nominal cooling power
Internal flow	Nominal coolant flow rate from the liquid cooling unit to the drive modules
External flow	Nominal coolant flow rate to the liquid cooling unit from an external cooling circuit

Losses

$P_{\text{loss total}}$	Power loss conducted to coolant and emitted to air
$P_{\text{loss coolant}}$	Power loss conducted to coolant
$P_{\text{loss air}}$	Power loss emitted to air (ambient room)
P_{drop}	Pressure loss in external cooling unit

Dimensions

ACS880 air-cooled multidrives

Frame size		Height (mm)	Width (mm)	Depth (mm)	Weight (kg)
ACS880-207 IGBT supply unit (ISU). Dimensions include ACU, ICU, ISU and filter.					
R8i+BLCL-13-5	Limited scope ¹⁾	2145	1000	636	810
	Standard scope ¹⁾	2145	1600	636	1300
R8i+BLCL-15-5	Limited scope ¹⁾	2145	1000	636	860
	Standard scope ¹⁾	2145	1600	636	1300
2×R8i+BLCL-24-5	1040A-5	2145	1800	636	1600
	1130A-3, 1330A-3	2145	2000	636	1720
2×R8i+BLCL-25-5		2145	2000	636	1720
3×R8i+2×BLCL-24-5		2145	2600	636	2410
4×R8i+2×BLCL-25-5		2145	2800	636	2820
6×R8i+3×BLCL-25-5		2145	4000	636	3960
R8i+BLCL-13-7		2145	1600	636	1300
R8i+BLCL-15-7		2145	1600	636	1300
2×R8i+BLCL-24-7		2145	1800	636	1600
2×R8i+BLCL-25-7		2145	1800	636	1600
3×R8i+2×BLCL-25-7		2145	2600	636	2210
4×R8i+2×BLCL-25-7		2145	2800	636	2820
6×R8i+3×BLCL-25-7		2145	3600	636	3720
8×R8i+4×BLCL-25-7		2145	5100	636	4860
10×R8i+5×BLCL-25-7		2145	5900	636	5760
ACS880-907 regenerative rectifier unit (RRU). Dimensions include ACU, ICU, RRU and filter.					
1×R8i+BL-15-5		2145	1600	636	1275
2×R8i+BL-25-5		2145	2000	636	1615
4×R8i+2×BL-25-5	2310A-3/5	2145	2800	636	2610
	3460A-3/5	2145	3200	636	2850
6×R8i+3×BL-25-5		2145	4000	636	3645
1×R8i+BL-15-7		2145	1600	636	1275
2×R8i+BL-25-7		2145	2000	636	1615
4×R8i+2×BL-25-7	2310A-7	2145	2800	636	2610
	3460A-7	2145	3200	636	2850
6×R8i+3×BL-25-7		2145	4000	636	3645

¹⁾ In addition to standard ACS880 multidrive offering, limited scope offering is available with special configuration for 400 V and 500 V, R1i to R7i inverters.

²⁾ 2315 mm for IP54 and 2051 mm for IPxxR.

An additional 10 mm required for marine supports.

³⁾ Width and weight depend on the amount of inverter units.

With option own compartment (+C204) 400 mm for max. 3 inverters.

⁴⁾ Top exit with backpack for R1i to R7i, additional depth is 130 mm.

⁵⁾ Width and weight depend on the amount of inverter units.

With option own compartment (+C204) 500 mm for max. 2 R5i inverters.

⁶⁾ 300 mm is required for drive control unit (DCU).

One DCU can be used for two drive units.

⁷⁾ Top exit with backpack for n×R8i, additional depth is 190 mm.

⁸⁾ 2315 mm for IP54, and 2051 mm for IPXXR

⁹⁾ It is possible to connect multiple DC/DC converter units in parallel. Please see hardware manual (doc no 3AXD50000023644) for more detailed information.

¹⁰⁾ Please see hardware manual for further details.

Frame size		Height (mm)	Width (mm)	Depth (mm)	Weight (kg)
ACS880-307 diode supply unit (DSU). Dimensions include ACU, ICU and DSU.					
6-pulse diode					
D6D		2145	400	636	300
D7D		2145	400	636	350
D8D		2145	700	636	550
D8T		2145	1400	636	850
2×D8T	1060A-7	2145	1400	636	1130
	1210A-3/5, 1820A-3/5, 1520A-7	2145	1600	636	1130
	3×D8T	2145	2000	636	1560
4×D8T	690 V drives	2145	2400	636	1940
	400/500 V drives	2145	2800	636	2140
5×D8T		2145	3000	636	2420
6×D8T		2145	3200	636	2700
12-pulse diode					
2×D7T		2145	1800	636	900
2×D8T		2145	1800	636	1180
4×D8T	2430A-3/5, 2130A-7	2145	2400	636	1840
	3640A-3, 3650A-5 3040A-7	2145	3000	636	2040
6×D8T		2145	3400	636	2900
ACS880-107 inverter unit (INU)					
R1i		2145 ²⁾	400 to 1000 ³⁾	636 ⁴⁾	240 to 490 ³⁾
R2i		2145 ²⁾	400 to 1000 ³⁾	636 ⁴⁾	240 to 490 ³⁾
R3i		2145 ²⁾	400 to 1000 ³⁾	636 ⁴⁾	240 to 490 ³⁾
R4i		2145 ²⁾	400 to 1000 ³⁾	636 ⁴⁾	240 to 490 ³⁾
R5i		2145 ²⁾	300 to 500 ⁵⁾	636	200 to 320 ⁵⁾
R6i		2145 ²⁾	400	636 ⁴⁾	250
R7i		2145 ²⁾	400	636 ⁴⁾	250
R8i		2145 ²⁾	400 ⁶⁾	636 ⁷⁾	320
2×R8i		2145 ²⁾	600 ⁶⁾	636 ⁷⁾	510
3×R8i		2145 ²⁾	800 ⁶⁾	636 ⁷⁾	660
4×R8i		2145 ²⁾	1200 ⁶⁾	636 ⁷⁾	1020
5×R8i		2145 ²⁾	1400 ⁶⁾	636 ⁷⁾	1170
6×R8i		2145 ²⁾	1600 ⁶⁾	636 ⁷⁾	1320
7×R8i		2145 ²⁾	2000 ⁶⁾	636 ⁷⁾	1680
8×R8i		2145 ²⁾	2200 ⁶⁾	636 ⁷⁾	1830
9×R8i		2145 ²⁾	2400 ⁶⁾	636 ⁷⁾	1980
10×R8i		2145 ²⁾	2800 ⁶⁾	636 ⁷⁾	2340
ACS880-1607 DC/DC converter⁹⁾					
R8i		2145 ⁸⁾	800	636	650
R8i		2145 ⁸⁾	800	636	680 ¹⁰⁾
2×R8i		2145 ⁸⁾	1600	636	1300
2×R8i		2145 ⁸⁾	1600	636	1360 ¹⁰⁾

Standard interface and extensions for plug-in connectivity

—
01
Control unit ZCU
—
02
Example of
a typical multidrives
input/output
connection diagram.
Variations maybe
possible. For further
information, please
see the ACS880
user manual.

ACS880 multidrives offer a wide range of standard interfaces including extensive selection of I/O connections, Safe Torque Off (STO) and a galvanically isolated RS485 link that can be configured as either Modbus RTU or high speed drive-to-drive link.

In addition, the drive control unit (ZCU/BCU) has three option slots that can be used for extensions, including communication protocol adapters, input/output extension modules, feedback modules, and a safety functions module. For I/O extensions, see page 49.

Control unit ZCU for inverters (R1i to R7i) and diode supply unit (D6D to D8D) comes with three option slots for extension option modules.

Control unit BCU is used for inverters (nxR8i), IGBT supply unit, regenerative rectifier unit, DC/DC converter, brake units and diode supply unit (frame nxDXT). BCU comes with integrated branching unit, and three option slots with an additional slot for DDCCS communication option.



Control connections	Description
2 analog inputs (XAI)	Current input: -20 to 20 mA, R_{in} : 100 ohm Voltage input: -10 to 10 V, R_{in} > 200 kohm Resolution: 11 bit + sign bit
2 analog outputs (XAO)	0 to 20 mA, R_{load} < 500 ohm Frequency range: 0 to 300 Hz Resolution: 11 bit + sign bit
6 digital inputs (XDI)	Input type: NPN/PNP (DI1 to DI5), NPN (DI6) DI6 (XDI:6) can alternatively be used as an input for a PTC thermistor.
Digital input interlock (DIIL)	Input type: NPN/PNP
2 digital inputs/outputs (XDIO)	As input: 24 V logic levels: "0" < 5 V, "1" > 15 V R_{in} : 2.0 kohm Filtering: 0.25 ms As output: Total output current from 24 V DC is limited to 200 mA Can be set as pulse train input and output
3 relay outputs (XRO1, XRO2, XRO3)	250 V AC/30 V DC, 2 A
Safe torque off (XSTO)	For the drive to start, both connections must be closed, only to be used in inverter units
Drive-to-drive link (XD2D)	Physical layer: EIA-485
Built-in Modbus	EIA-485
Assistant control panel/PC tool connection	Connector: RJ-45

Relay outputs		XRO1, XRO2, XRO3	
Ready	NO	13	
250 V AC/30 V DC	COM	12	
2 A	NC	11	
Running	NO	23	
250 V AC/30 V DC	COM	22	
2 A	NC	21	
Faulted (-1)	NO	33	
250 V AC/30 V DC	COM	32	
2 A	NC	31	
External power input		XPOW	
24 V DC, 2 A	GND	2	
	+24VI	1	
Reference voltage and analog inputs		J1, J2, XAI	
AI1/AI2 current/voltage selection	AI1:U	AI2:U	
	AI1:I	AI2:I	
By default not in use. 0(4) to 20 mA, $R_{in} = 100 \text{ ohm}$	AI2-	7	
	AI2+	6	
Speed reference 0(2) to 10 V, $R_{in} > 200 \text{ kohm}$	AI1-	5	
	AI1+	4	
Ground	AGND	3	
-10 V DC, $R_L 1 \text{ to } 10 \text{ kohm}$	-VREF	2	
10 V DC, $R_L 1 \text{ to } 10 \text{ kohm}$	+VREF	1	
Analog outputs		XAO	
Motor current 0 to 20 mA, $R_L < 500 \text{ ohm}$	AGND	4	
	AO2	3	
Motor speed rpm 0 to 20 mA, $R_L < 500 \text{ ohm}$	AGND	2	
	AO1	1	
Drive-to-drive link		J3, XD2D	
Drive-to-drive link termination	ON <input type="checkbox"/> OFF <input type="checkbox"/>	Shield	4
Drive-to-drive link or built-in Modbus	BGND	3	
	A	2	
	B	1	
Safe torque off		XSTO	
Safe torque off. Both circuits must be closed for the drive to start.	IN2	4	
	IN1	3	
	SGND	2	
	OUT	1	
Digital inputs		XDI	
By default not in use	DI6	6	
Constant speed 1 select (1=on)	DI5	5	
Acceleration and deceleration select	DI4	4	
Reset	DI3	3	
Forward (0)/Reverse (1)	DI2	2	
Stop (0)/Start (1)	DI1	1	
Digital input/outputs		XDIO	
Output: Running	DIO2	2	
Output: Ready	DIO1	1	
Ground selection		XD24	
Digital input/output ground	DIOGND	5	
+24 V DC 200 mA	+24VD	4	
Digital input ground	DICOM	3	
+24 V DC 200 mA	+24VD	2	
Digital interlock	DIIL	1	
Digital interlock	DIIL	1	
Safety functions module connection		X12	
Control panel/PC connection		X13	
Memory unit connection		X205	

Communication and connectivity

Fast and reliable communication

The **F-series fieldbus adapter modules** are flexible, plug-in adapters that provide fast and simple universal connectivity to all major controllers. Universal connectivity means ABB low voltage drives connect to automation controllers and communication networks, allowing users to choose the best network to meet their needs.

- Reduces mechanical and electrical cost
- Decrease in downtime
- Increase in productivity
- Diminished start-up costs
- Lower maintenance and diagnostic costs
- Quick access to networked drives with PC-based start-up and maintenance software tools
- Reductions in wiring costs compared to traditional I/O connections

Industrial automation plant – different network possibilities and their secure deployment

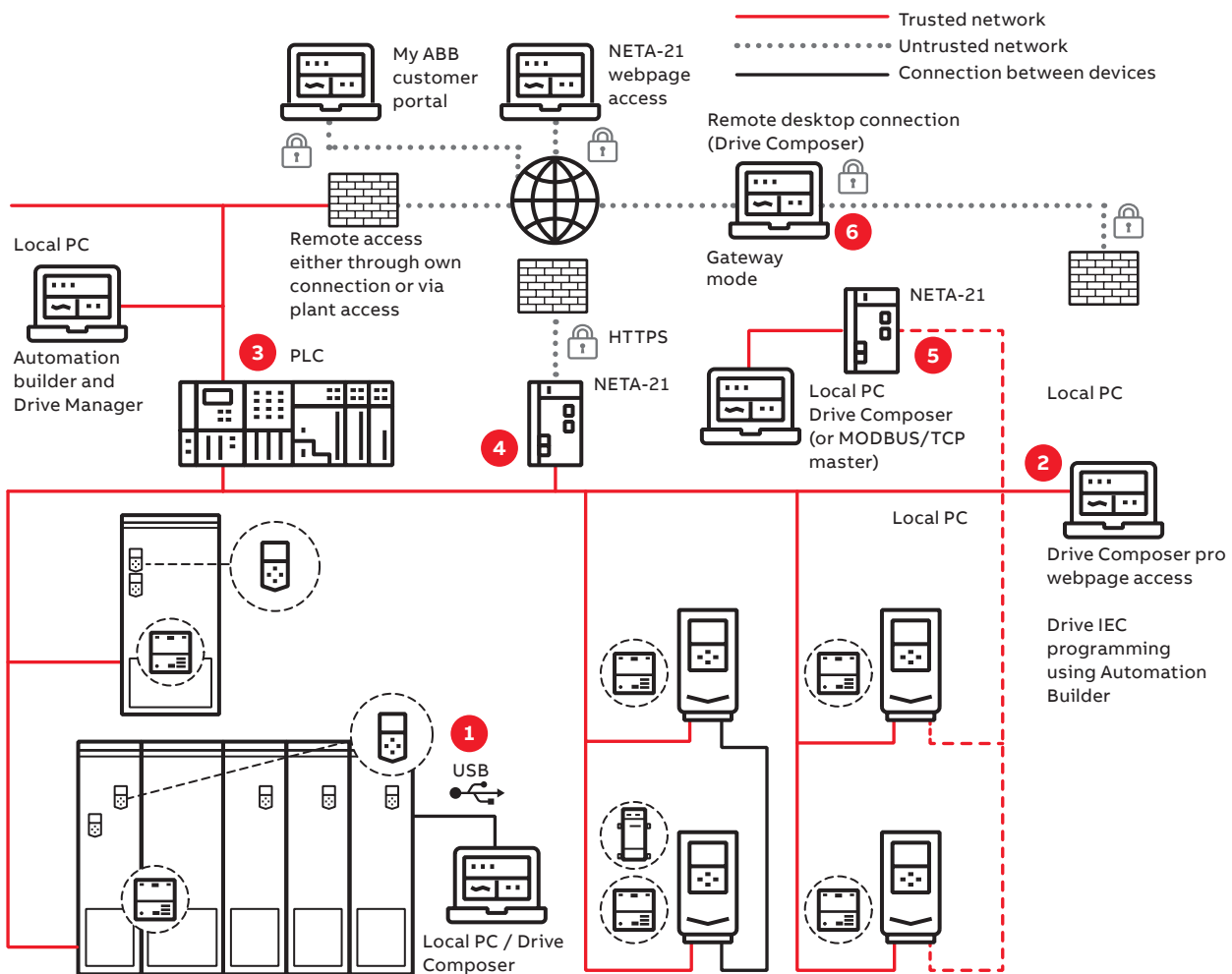

1. Local connections (point-to-point serial communication, e.g. USB) or
2. Shared (with control) upper-level physical fieldbus network (e.g., PROFINET) using Ethernet tool communication and/or
3. Communicating also through PLC system using Drive Manager device tool or
4. NETA-21 remote monitoring tool web interface or
5. NETA-21 acting as a gateway between or
6. Third-party remote desktop connection.

Connectivity to automation systems

—
01
ACS880 is compatible with many communication protocols
—
02
Input/output extension modules

Communication protocol adapters

ACS880 industrial drives are compatible with a wide range of communication protocols. The drive comes with a Modbus RTU fieldbus interface as standard.

The ACS880 supports two different communication connections simultaneously and offers the possibility for redundant communication. PROFIsafe (functional safety over PROFINET) is also supported.

Communication protocol adapters

Option code	Ordering code for loose item	Communication protocol	Adapter
+K451	68469341	DeviceNet™	FDNA-01
+K454	68469325	PROFIBUS DP, DPV0/DPV1	FPBA-01
+K457	68469376	CANopen®	FCAN-01
+K458	3AUA0000031336	Modbus RTU	FSCA-01
+K462	3AUA0000094512	ControlNet	FCNA-01
+K469	3AUA0000072069	EtherCAT®	FECA-01
+K470	3AXD5000019239	POWERLINK	FEPL-02
+K491	3AXD5000049964	Modbus/TCP	FMBT-21
+K492	3AXD50000192779	PROFINET IO	FPNO-21 ¹⁾
+K490	3AXD50000192786	EtherNet/IP	FEIP-21
+Q986	3AXD50000112821	PROFIsafe safety functions module	FSPS-21

¹⁾ For the PROFIsafe to work the PROFINET adapter module (FPNO-21) and the safety functions module FSO-12 (+Q973) or FSO-21 (+Q972) are required. The FPNO-21 adapter module enables PROFINET system redundancy S2 allowing the drive to establish connection with two control PLCs in a redundant manner.



01

02

Input/output extension modules

Standard input and output can be extended by using optional analog and digital input/output extension modules. The modules are easily installed in the extension slots located on the drive.

If there are not enough I/O extension slots in the drive, the FEA-03 module can increase the number of slots. The FEA-03 has two option slots for digital I/O extensions and speed feedback interface modules. The connection to the control unit is via an optical fiber link, and the adapter can be mounted on a DIN rail (35 × 7.5 mm).

Analog and digital input/output extension modules

Option code	Ordering code for loose item	Description	I/O module
+L501	68805368	4×DI/O, 2×RO	FIO-01
+L500	68805384	3×AI (mA/V), 1×AO (mA), 2×DI/O	FIO-11
+L515	3AUA0000108669	2×F-type option extension slots	FEA-03
+L525	3AUA0000141436	2×AI (mA/V), 2×AO (mA)	FAIO-01
+L526	3AUA0000141438	3×DI (up to 250 V DC or 230 V AC), 2×RO	FDIO-01

PROFINET S2 system redundancy for ABB drives

System redundancy is a high-priority requirement in process industry and infrastructure installations where the system must be operational even during component breakdowns and malfunctioning. The interruption of a continuous production process could potentially lead to large financial losses or safety hazards. Thanks to the new PROFINET S2 system redundancy of ABB drives, the unwanted downtime can be minimized. This leads to better process control with improved productivity.

PROFINET system redundancy S2 is now available for ABB drives with the optional PROFINET interface module FPNO-21. It allows the drive to establish connection with two control PLCs in a redundant manner.

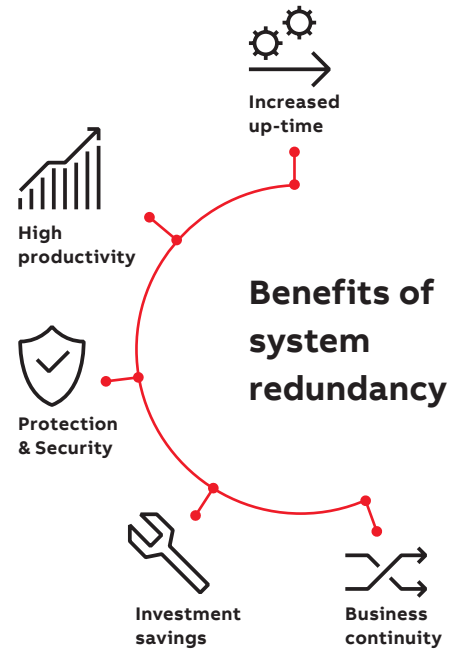

PROFINET IO
2 ports interface module.
Certified according to
Conformance Class B (CC-B)

SNTP Time synchronization

For all-compatible drives



Ethernet tool network
PROFINET IO at the same time
with Drive Composer pro

PROFINET Shared Device
PROFIsafe support with FSO-12/-21
safety functions module

PROFINET S2 system redundancy

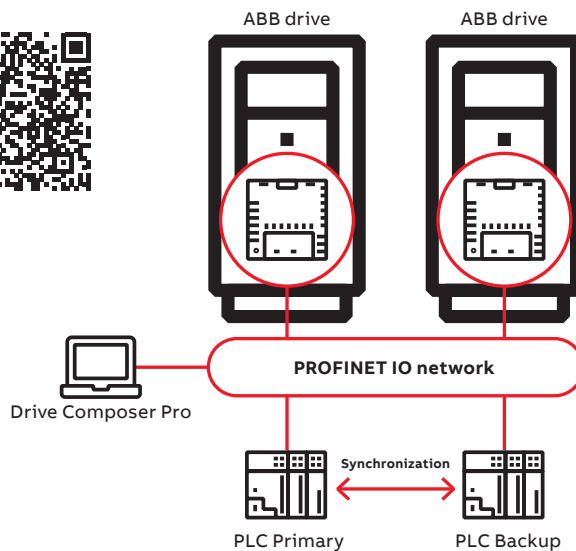

Feedback interface and DDCS communication options

—
01
FEN-01 TTL encoder
interface module
—
02
FDCO-01 DDCS
communication module

Speed feedback interfaces for precise process control

ACS880 drives can be connected to various feedback devices, such as HTL pulse encoders, TTL pulse encoders, absolute encoders and resolvers. The optional feedback module is installed in the option slot on the drive. It is possible to use two feedback modules at the same time, either of the same type or different types*).

*) Excluding FSE-31.



—
01

Feedback interface modules

Option code	Ordering code for loose item	Description	Feedback module
+L517	68805422	2 inputs (TTL pulse encoder), 1 output	FEN-01
+L518	68805830	2 inputs (SinCos absolute, TTL pulse encoder), 1 output	FEN-11
+L516	68805848	2 inputs (Resolver, TTL pulse encoder), 1 output	FEN-21
+L502	68978955	1 input (HTL pulse encoder), 1 output	FEN-31
+L521	3AXD5000023272	Pulse encoder interface for functional safety (for more details see section "Safety options")	FSE-31

DDCS communication option modules

The FDCO-0X optical DDCS communication options are add-on modules on the ACS880 industrial drives control unit. The modules include connectors for two fiber optic DDCS channels. The FDCO-0X modules make it possible to perform master-follower and AC800 M communication. Alternative way for drive to drive communication is to use the standard RS485 connection.



—
02

Optical communication modules

Option code	Ordering code for loose item	Description	Module
+L503	3AUA0000107392	Optical DDCS (10 Mbd/10 Mbd)	FDCO-01
+L508	3AUA0000107393	Optical DDCS (5 Mbd/10 Mbd)	FDCO-02

Safety options

—
01
FSO-12 safety
functions module

Integrated safety

Integrated safety reduces the need for external safety components, simplifying configuration and reducing installation space. The safety functionality is a built-in feature of the ACS880, with safe torque off (STO) as standard. The STO function corresponds to an uncontrolled stop in accordance with stop category 0 of EN 60204-1. Additional safety functions can be commissioned with the optional and compact safety functions module. ACS880 drives offer functional safety with or without encoder. The drive's functional safety is designed in accordance with EN/IEC 61800-5-2 and complies with the requirements of the European Union Machinery Directive (2006/42/EC).

Safety functions are designed to the multidrives on project specific requirements.

The safety functions are certified by TÜV Nord and comply with the highest performance requirements (SIL 3 / PL e) in machinery safety.¹⁾

The safety functions module can also be ordered separately and installed afterwards to the drive.

PROFIsafe safety functions module, FSPS-21, with integrated PROFIsafe, and PROFINET IO connection supports STO and SS1-t safety functions. Since the functions are automatically configured, no additional safety settings are required in the drive.

Safety functions modules, FSO-12 and FSO-21, support a wide range of safety functions. Configuration of the functions is done with



—
01

the Drive Composer Pro PC tool, which provides an easy-to-use graphical user interface. Larger safety systems can be built using PROFIsafe over PROFINET connection between a safety PLC (such as AC500-S) and the ACS880 drive. The connection is achieved by adding a PROFINET adapter, FPNO-21, to the drive.

Supported safety functions:

- Encoderless: SS1-t, SS1-r, SLS, SBC, SMS, SSE, POUS, STO
- With encoder (requires FSO-21 + FSE-31): SDI, SSM, SS1-t, SS1-r, SLS, SBC, SMS, SSE, POUS, STO

Pulse encoder interface module, FSE-31, provides safe encoder data to the safety functions module, and can simultaneously be used as a feedback device for the drive. FSE-31 requires an FSO-21 safety functions module and supports HTL encoders.

Thermistor protection modules, FPTC-01 and FPTC-02

Safe temperature monitoring (STM) can be achieved by using FPTC thermistor protection modules¹⁾.

Safety function modules

Option code	Description	Safety module
+Q979 +Q973/ +Q972	Emergency Stop, configurable stop cat. 0 or 1; with STO, with safety functions module ²⁾	FSO-12/-21
+Q966 +Q973/+Q972	Safely-limited speed (SLS) with safety functions module (without encoder) ²⁾	FSO-12/-21
+Q965 + Q972 +L521	Safely-limited speed (SLS) with FSO-21 and with encoder FSE-31 ²⁾	FSO-21 and FSE-31
+Q950 +Q973/ +Q972	Prevention of unexpected startup (POUS) with safety functions module ²⁾	FSO-12/-21
+Q982 +Q972 +K492	PROFIsafe safety communication to be used together with FSO-21: forces to select a functional safety module and PROFINET adapter, FPNO-21	FSO-21 and FPNO-21
+L536	Thermistor protection module FPTC-01 ¹⁾	FPTC-01
+L537 +Q971	ATEX-certified thermistor protection module FPTC-02, Ex II (2) GD ¹⁾	FPTC-02

¹⁾ Thermistor modules comply with SIL 2 / PL c.

²⁾ Safety data and safety levels can be calculated for engineered solutions for multidrives cabinets as option. Safety level depends on configuration.

Safety function	Description	Supported functions		
		FSO-12 without encoder	FSO-21 + FSE-31 + HTL encoder	
Safe stop 1 SS1-t SS1-r	Brings the machine to a stop using a monitored deceleration ramp. It is typically used in applications where the machinery motion needs to be brought to a stop (stop category 1) in a controlled way before switching over to the no-torque (STO) state	x (SS1-t) (SS1-r)	x (SS1-t) (SS1-r)	
Safe stop emergency SSE	Can be configured to, upon request, either activate STO instantly (category 0 stop), or first initiate motor deceleration and then, once the motor has stopped, activate the STO (category 1 stop).	x	x	
Safe brake control SBC	Provides a safe output for controlling the motor's external (mechanical) brakes, together with STO.	x	x	
Safely-limited speed SLS	Ensures that the specified speed limit of the motor is not exceeded. This allows machine interaction to be performed at slow speed without stopping the drive. The safety function module comes with four individual SLS settings for speed monitoring.	x	x	
Safe maximum speed SMS	Monitors that the speed of the motor does not exceed the configured maximum speed limit.	x	x	
Prevention of unexpected start-up POUS	Ensures that the machine remains stopped when people are in the danger area.	x	x	
Safe direction SDI	Ensures that rotation is allowed only in the selected direction (available only with FSO-21 and FSE-31).		x	
Safe speed monitor SSM	Provides a safe output signal to indicate whether the motor speed is between user-defined limits (available only with FSO-21).		x	
Safe torque off STO	Brings the drive safely to a no-torque state, i.e. switches off the drive output to the motor, motor speed then coasts to a stop. ACS880 has safe torque off as standard.	x	x	

Summary of features and options

ACS880 air-cooled multidrivess

	Option code	ACS880 -107 INU R1i to nxR8i	ACS880 -207 ISU nxR8i	ACS880 -307 DSU D6D to D8D 6-pulse	ACS880 -307 DSU D7T and nxD8T 6 or 12-pulse	ACS880 -907 RRU nxR8i	ACS880 -607 brake unit nxR8i	ACS880 -1607 DC/DC nxR8i
Mounting								
Free-standing		●	●	●	●	●	●	●
Cabling								
Supply bottom entry		-	●	●	●	●	-	-
Supply top entry		-	□	□	□	□	-	-
Inverter bottom exit		●	-	-	-	-	●	●
Inverter top exit		□	-	-	-	-	□	□
Degree of protection								
IP22 (UL type 1)		●	●	●	●	●	●	●
IP42 (UL type 1)		□	□	□	□	□	□ ¹⁾	□ ¹⁾
IP54 (UL type 12)		□	□	□	□	□	□ ¹⁾	□ ¹⁾
Motor control								
DTC motor control		●	-	-	-	-	-	-
Control panel								
Intuitive control panel		□	□	□	□	□	□ ²⁾	□
EMC filters								
EMC 1st environment, restricted distribution, C2, grounded network (TN)	+E202	-	□	-	□ ⁴⁾	□	-	-
EMC 2nd environment, C3, grounded (TN) and ungrounded network (IT)	+E210	□ ⁵⁾	□ ⁵⁾	□ ⁵⁾	□ ⁵⁾	□ ⁵⁾	□ ⁵⁾	□ ⁵⁾
Line filter								
AC or DC choke		-	-	●	●	-	-	-
Advanced line harmonic filter LCL		-	●	-	-	-	-	-
Advanced line harmonic filter L		-	-	-	-	●	-	-
Output filter								
Common mode filter	+E208	● ⁶⁾	● ⁶⁾	-	-	● ⁶⁾	●	●
Du/dt filters	+E205	● ⁷⁾	●	-	-	●	●	●
Braking (see braking unit table)								
Incoming unit apparatus								
Disconnecter		-	● ⁸⁾	●	● ⁹⁾	● ¹⁰⁾	-	-
Air circuit breaker	+F255	-	● ¹¹⁾	●	● ⁹⁾	● ¹²⁾	-	-
Line contactor	+F250	-	● ⁸⁾	□	-	● ¹⁰⁾	-	-
Earthing switch	+F259	-	□	□	□	□	-	-
Inverter units								
DC switch	+F286	□ ¹³⁾	-	-	-	-	□ ¹⁴⁾	□
R1i - R5i in an own compartment	+C204	□	-	-	-	-	-	-

- Standard
- Selectable option, with plus code
- Selectable option, external, no plus code

ACS880 air-cooled multidrives

	Option code	ACS880 -107 INU R1i to nxR8i	ACS880 -207 ISU nxR8i	ACS880 -307 DSU D6D to D8D 6-pulse	ACS880 -307 DSU D7T and nxD8T 6 or 12-pulse	ACS880 -907 RRU nxR8i	ACS880 -607 brake unit nxR8i	ACS880 -1607 DC/DC nxR8i
Software								
Primary control program		●	-	-	-	-	-	-
Drive application programming based on IEC 61131-3 using Drive Application Builder (available for primary control program)	+N8010	□ ³⁾	□ ³⁾	-	-	-	-	-
Application control program for winder	+N5000	□	-	-	-	-	-	-
Application control program for crane	+N5050	□	-	-	-	-	-	-
Application control program for winch	+N5100	□	-	-	-	-	-	-
Application control program for centrifuge/decanter	+N5150	□	-	-	-	-	-	-
Application control program for PCP pump	+N5200	□	-	-	-	-	-	-
Application control program for test bench	+N5300	□	-	-	-	-	-	-
High speed test bench ²⁵⁾	+P967	□	-	-	-	-	-	-
Application control program for override control	+N5450	□	-	-	-	-	-	-
Application control program for ESP pumps	+N5600	□	-	-	-	-	-	-
Application control program for position control	+N5700	□ ²⁴⁾	-	-	-	-	-	-
Support for asynchronous motor		●	-	-	-	-	-	-
Support for permanent magnet motor		●	-	-	-	-	-	-
Support for Synchronous reluctance motor (SynRM)	+N7502	□	-	-	-	-	-	-
Application control program for LV synchronous machine	+N8052	□	-	-	-	-	-	-
Optimal grid control of IGBT supply control program (grid converter)	+N8053	-	□	-	-	-	-	-
High speed license. Allows high speed operation above 598 Hz output frequency.	+N8200	□	-	-	-	-	-	-
Approvals								
CE, UKCA		●	●	●	●	●	●	●
UL, cUL		□	□	□	□	□	□	□
CSA		□	□	□	□	□	□	□
EAC/GOST R ¹⁵⁾		●	●	●	●	●	●	●
RoHS		●	●	●	●	●	●	●
RCM		●	●	●	●	●	●	●
Marine type approvals ¹⁶⁾	+C132	□ ¹⁷⁾	□	-	□	-	□	□
TÜV nord certificate for STO		●	-	-	-	-	-	-
TÜV nord certificate for FSO-12	+Q973	□	-	-	-	-	-	-
TÜV nord certificate for FSO-21	+Q972	□	-	-	-	-	-	-
TÜV nord certificate for FSE-31	+L521	□	-	-	-	-	-	-
Eurofins ATEX protective device certificate	+Q971 +L513/ +L514 or +Q971 +L537	□	-	-	-	-	-	-
SEMI F47		●	●	●	●	●	●	●

- Standard
- Selectable option, with plus code
- Selectable option, external, no plus code

ACS880 air-cooled multidrives

	Option code	ACS880 -107 INU R1i to nxR8i	ACS880 -207 ISU nxR8i	ACS880 -307 DSU D6D to D8D 6-pulse	ACS880 -307 DSU D7T and nxD8T 6 or 12- pulse	ACS880 -907 RRU nxR8i	ACS880 -607 brake unit nxR8i	ACS880 -1607 DC/DC nxR8i
Safety functions ²³⁾								
Safe torque off (STO)		●	-	-	-	-	-	-
Safety functions module, FSO-12, without encoder, configurable functions: - Safe stop 1 (SS1-t, SS1-r) - Safely-limited speed (SLS) - Safe brake control (SBC) - Safe maximum speed (SMS) - Safe stop emergency (SSE) - Prevention of unexpected start-up (POUS) - Safe torque off (STO)	+Q973	□	-	-	-	-	-	-
Safety functions module, FSO-21, with encoder support, configurable functions: - Safe stop 1 (SS1-t, SS1-r) - Safely-limited speed (SLS) - Safe brake control (SBC) - Safe maximum speed (SMS) - Safe stop emergency (SSE) - Prevention of unexpected start-up (POUS) - Safe direction (SDI), requires encoder feedback, FSE-31 - Safe speed monitoring (SSM) - Safe torque off (STO)	+Q972	□	-	-	-	-	-	-
Pulse encoder interface module, FSE-31	+L521	□	-	-	-	-	-	-
Prevention of unexpected start-up with safety relay(s)	+Q957	□	-	-	-	-	-	-
Prevention of unexpected start-up with STO and safety functions module (FSO-12/-21)	+Q950 +Q973/ +Q972	□	-	-	-	-	-	-
Emergency stop, category 0 with opening the main contactor/breaker, with safety relay	+Q951	-	□	□	□	□	-	-
Emergency stop, category 1 with opening the main contactor/breaker, with safety relay	+Q952	-	□	□	□	□	-	-
Emergency stop, category 0 with STO, with safety relay	+Q963	-	□	□	□	□	-	-
Emergency stop, category 1 with STO, with safety relay	+Q964	-	□	□	□	□	-	-
Emergency stop, configurable category 0 or 1 with STO and safety functions module (FSO-12/-21)	+Q979 +Q973/ +Q972	-	□	□	□	□	-	-
PROFIsafe over PROFINET with safety functions module (FSO-21) and FPNO-21	+Q982 +Q972 +K492	□	-	-	-	-	-	-
Safely-limited speed (SLS) without encoder with FSO-12/-21 (encoderless)	+Q966 +Q973 +Q972	□	-	-	-	-	-	-
Safely-limited speed (SLS) with FSO-21 and encoder FSE-31	+Q965 +Q972 +L521	□	-	-	-	-	-	-
ATEX thermal motor protection for PTC/PT100, EX II (2) GD	+Q971 +L513/ +L514	□	-	-	-	-	-	-
FPTC-01 thermistor protection module	+L536	□	-	-	-	-	-	-
ATEX certified thermistor protection module, FPTC-02, EX II (2) GD	+L537 +Q971	□	-	-	-	-	-	-

- Standard
- Selectable option, with plus code
- Selectable option, external, no plus code

ACS880 air-cooled multidrives

	Option code	ACS880 -107 INU R1i to nxR8i	ACS880 -207 ISU nxR8i	ACS880 -307 DSU D6D to D8D 6-pulse	ACS880 -307 DSU D7T and nxD8T 6 or 12- pulse	ACS880 -907 RRU nxR8i	ACS880 -607 brake unit nxR8i	ACS880 -1607 DC/DC nxR8i
Earth fault protection								
Earth fault monitoring, earthed mains		●	●	–	–	●	–	–
Earth fault monitoring, unearthed mains	+Q954	–	□	□	□	□	–	–
Control connections (I/O) and communications								
2 pcs analog inputs, programmable, galvanically isolated		●	●	●	●	●	● ²⁾	●
2 pcs analog outputs, programmable		●	●	●	●	●	● ²⁾	●
6 pcs digital inputs, programmable, galvanically isolated – can be divided into two groups		●	●	●	●	●	● ²⁾	●
2 pcs digital inputs/outputs		●	●	●	●	●	● ²⁾	●
1 pcs digital input interlock		●	●	●	●	●	● ²⁾	●
3 pcs relay outputs		●	●	●	●	●	● ²⁾	●
Drive-to-drive link/Built-in Modbus	●	●	●	●	●	●	● ²⁾	●
Assistant control panel/PC tool connection		●	●	●	●	●	● ²⁾	●
Possibility for external power supply for control unit		□	□	□	□	□	□ ²⁾	□
Built-in I/O extension and speed feedback modules: for more details see sections: "Input/output extension modules", "Speed feedback interfaces for precise process control" and "DDCS communication option modules" ¹⁸⁾		□	□	□	□	□	□ ²⁾	□
Built-in adapters for several communication protocols: for more details see section "Communication protocol adapters" ¹⁹⁾		□	□	□	□	□	□ ²⁾	□

- Standard
- Selectable option, with plus code
- Selectable option, external, no plus code

ACS880 liquid-cooled multidrives

	Option code	ACS880 -107LC INU R7i, nxR8i	ACS880 -207LC ISU R7i, nxR8i	ACS880 -307LC DSU nxD8T	ACS880 -607LC brake unit	ACS880 -1607LC DC/DC nxR8i
Mounting						
Free-standing		●	●	●	●	●
Cabling						
Supply bottom entry		–	●	●	–	–
Supply top entry		–	□	□	–	–
Inverter bottom exit		●	–	–	●	●
Inverter top exit		□	–	–	□	□
Degree of protection						
IP22 (UL type 1)		–	–	–	–	–
IP42 (UL type 1)		●	●	●	●	●
IP54 (UL type 12)		□	□	□	□	□
Motor control						
DTC motor control		●	–	–	–	–
Control panel						
Intuitive control panel		□	□	□	□ ²⁾	□
EMC filters						
EMC 1st environment, restricted distribution, C2, grounded network (TN)	+E202	–	□	□	–	–
EMC 2nd environment, C3, grounded (TN) and ungrounded network (IT)	+E210	□ ⁵⁾	□ ⁵⁾	□ ⁵⁾	□ ⁵⁾	□ ⁵⁾
Line filter						
AC or DC choke		–	–	●	–	–
Advanced line harmonic filter LCL		–	●	–	–	–
Advanced line harmonic filter L		–	–	–	–	–
Output filter						
Common mode filter	+E208	●	●	–	●	●
Du/dt filters	+E205	●	●	–	●	●
Braking (see braking unit table)						
Incoming unit apparatus						
Disconnecter		–	–	–	–	–
Air circuit breaker	+F255	–	●	●	–	–
Line contactor	+F250	–	–	–	–	–
Earthing switch	+F259	–	□	□	–	–
Inverter units						
DC switch	+F286	□	□	–	□ ¹⁴⁾	□
R1i - R5i in an own compartment	+C204	–	–	–	–	–

● Standard

□ Selectable option, with plus code

■ Selectable option, external, no plus code

ACS880 liquid-cooled multidrives

	Option code	ACS880 -107LC INU R7i, nxR8i	ACS880 -207LC ISU R7i, nxR8	ACS880 -307LC DSU nxD8T	ACS880 -607LC brake unit	ACS880 -1607LC DC/DC nxR8i
Software						
Primary control program		●	–	–	–	–
Drive application programming based on IEC 61131-3 using Drive Application Builder (available for primary control program)	+N8010	□ ³⁾	□ ³⁾	–	–	–
Application control program for winder	+N5000	□	–	–	–	–
Application control program for crane	+N5050	□	–	–	–	–
Application control program for winch	+N5100	□	–	–	–	–
Application control program for centrifuge/decanter	+N5150	□	–	–	–	–
Application control program for PCP pump	+N5200	□	–	–	–	–
Application control program for test bench	+N5300	□	–	–	–	–
Application control program for override control	+N5450	□	□	□	–	–
Application control program for ESP pumps	+N5600	□	–	–	–	–
Application control program for position control	+N5700	□ ²⁴⁾	–	–	–	–
Support for asynchronous motor		●	–	–	–	–
Support for permanent magnet motor		●	–	–	–	–
Support for Synchronous reluctance motor (SynRM)	+N7502	□	–	–	–	–
Application control program for LV synchronous machine	+N8052	□	–	–	–	–
Optimal grid control of IGBT supply control program (grid converter)	+N8053	–	□	–	–	–
High speed license. Allows high speed operation above 598 Hz output frequency.	+N8200	□	–	–	–	–
Approvals						
CE, UKCA		●	●	●	●	●
UL, cUL		□	□	□	□	–
CSA		□	□	□	□	–
EAC/GOST R ¹⁵⁾		●	●	●	●	●
RoHS		●	●	●	●	●
RCM		●	●	●	●	●
Marine type approvals ¹⁶⁾	+C132	□	□	□ ³⁾	□ ³⁾	□
TÜV nord certificate for STO		●	–	–	–	–
TÜV nord certificate for FSO-12	+Q973	□	–	–	–	–
TÜV nord certificate for FSO-21	+Q972	□	–	–	–	–
TÜV nord certificate for FSE-31	+L521	□	–	–	–	–
Eurofins ATEX protective device certificate	+Q971 +L513/ +L514 or +Q971 +L537	□	–	–	–	–
SEMI F47		●	●	●	●	●

● Standard

□ Selectable option, with plus code

■ Selectable option, external, no plus code

ACS880 liquid-cooled multidrives

	Option code	ACS880 -107LC INU R7i, nxR8i	ACS880 -207LC ISU R7i, nxR8	ACS880 -307LC DSU nxD8T	ACS880 -607LC brake unit	ACS880 -1607LC DC/DC nxR8i
Safety functions ²³⁾						
Safe torque off (STO)		●	–	–	–	–
Safety functions module, FSO-12, without encoder, configurable functions: - Safe stop 1 (SS1-t, SS1-r) - Safely-limited speed (SLS) - Safe brake control (SBC) - Safe maximum speed (SMS) - Safe stop emergency (SSE) - Prevention of unexpected start-up (POUS) - Safe torque off (STO)	+Q973	□	–	–	–	–
Safety functions module, FSO-21, with encoder support, configurable functions: - Safe stop 1 (SS1-t, SS1-r) - Safely-limited speed (SLS) - Safe brake control (SBC) - Safe maximum speed (SMS) - Safe stop emergency (SSE) - Prevention of unexpected start-up (POUS) - Safe direction (SDI), requires encoder feedback, FSE-31 - Safe speed monitoring (SSM) - Safe torque off (STO)	+Q972	□	–	–	–	–
Pulse encoder interface module, FSE-31	+L521	□	–	–	–	–
Prevention of unexpected start-up with safety relay(s)	+Q957	□	–	–	–	–
Prevention of unexpected start-up with STO and safety functions module (FSO-12/-21)	+Q950 +Q973/ +Q972	□	–	–	–	–
Emergency stop, category 0 with opening the main contactor/breaker, with safety relay	+Q951	–	□	□	–	–
Emergency stop, category 1 with opening the main contactor/breaker, with safety relay	+Q952	–	□	□	–	–
Emergency stop, category 0 with STO, with safety relay	+Q963	–	□	□	–	–
Emergency stop, category 1 with STO, with safety relay	+Q964	–	□	□	–	–
Emergency stop, configurable category 0 or 1 with STO and safety functions module (FSO-12/-21)	+Q979 +Q973/ +Q972	–	□	□	–	–
PROFIsafe over PROFINET with safety functions module (FSO-21) and FPNO-21	+Q982 +Q972 +K492	□	–	–	–	–
Safely-limited speed (SLS) without encoder with FSO-12/-21 (encoderless)	+Q966 +Q973 +Q972	□	–	–	–	–
Safely-limited speed (SLS) with FSO-21 and encoder FSE-31	+Q965 +Q972 +L521	□	–	–	–	–
ATEX thermal motor protection for PTC/PT100, EX II (2) GD	+Q971 +L513/ +L514	□	–	–	–	–
FPTC-01 thermistor protection module	+L536	□	–	–	–	–
ATEX certified thermistor protection module, FPTC-02, EX II (2) GD	+L537 +Q971	□	–	–	–	–

- Standard
- Selectable option, with plus code
- Selectable option, external, no plus code

ACS880 liquid-cooled multidrives

	Option code	ACS880 -107LC INU R7i, nxR8i	ACS880 -207LC ISU R7i, nxR8	ACS880 -307LC DSU nxD8T	ACS880 -607LC brake unit	ACS880 -1607LC DC/DC nxR8i
Earth fault protection						
Earth fault monitoring, earthed mains		●	●	●	–	–
Earth fault monitoring, unearthed mains	+Q954	–	□	□	–	–
Control connections (I/O) and communications						
2 pcs analog inputs, programmable, galvanically isolated		●	●	●	● ²⁾	●
2 pcs analog outputs, programmable		●	●	●	● ²⁾	●
6 pcs digital inputs, programmable, galvanically isolated – can be divided into two groups		●	●	●	● ²⁾	●
2 pcs digital inputs/outputs		●	●	●	● ²⁾	●
1 pcs digital input interlock		●	●	●	● ²⁾	●
3 pcs relay outputs		●	●	●	● ²⁾	●
Drive-to-drive link/Built-in Modbus	●	–	–	–	–	–
Assistant control panel/PC tool connection		●	●	●	● ²⁾	●
Possibility for external power supply for control unit		□	□	□	□ ²⁾	□
Built-in I/O extension and speed feedback modules: for more details see sections: “Input/output extension modules”, “Speed feedback interfaces for precise process control” and “DDCS communication option modules” ¹⁸⁾		□	□	□	□ ²⁾	□
Built-in adapters for several communication protocols: for more details see section “Communication protocol adapters” ¹⁹⁾		□	□	□	□ ²⁾	□

● Standard

□ Selectable option, with plus code

■ Selectable option, external, no plus code

– Not available

¹⁾ Not available for resistor D151

²⁾ Not available for 1-phase brake unit

³⁾ Pending

⁴⁾ Available only as 6-pulse D8T

⁵⁾ Conducted emission and immunity are fulfilled with standard filtering. Radiated emission and immunity are as option (cabinet construction).

⁶⁾ Standard for frame sizes R6i to 10×R8i

⁷⁾ Optional in frame sizes R1i to R8i and 400/500 V

⁸⁾ For ISU: 400 to 500 V disconnecter and contactor up to 2×R8i, 690 V disconnecter and contactor up to 3×R8i.

For bigger ISU frames: air-circuit breaker.

⁹⁾ For DSU 6-pulse, 400/500 V: disconnecter up to 3×D8T, air-circuit breaker ≥ 4×D8T.

For DSU 6-pulse, 690 V: disconnecter up to 4×D8T, air-circuit breaker ≥ 5×D8T.

For DSU 12-pulse: All 12-pulse DSUs have disconnecter as standard, air-circuit breaker is offered as an option.

¹⁰⁾ For RRU: Disconnecter and contactor up to 2×R8i, air-circuit breaker ≥ 4×R8i.

¹¹⁾ For ISU: 400 to 500 V air circuit breaker ≥ 3×R8i, 690 V air-circuit breaker ≥ 4×R8i

¹²⁾ For RRU: air circuit breaker >4×R8i

¹³⁾ R1i to R4i for cabinet, individual for R6i to n×R8i. Common for cabinet for R1i to R5i, individual for R6i to n×R8i.

¹⁴⁾ DC switch for 3-phase dynamic brake unit only

¹⁵⁾ EAC has replaced GOST R

¹⁶⁾ ACS880 marine type approval and type approved drives are listed at

¹⁷⁾ Marine type approval only available for frames R5i-nxR8i

¹⁸⁾ Three option slots are available for I/O extension, speed feedback, fieldbus and functional safety options.

The slot number for I/O and encoder options can be extended with FEA-03 option.

¹⁹⁾ Three option slots are available for I/O extension, speed feedback, communication protocol and functional safety options.

²³⁾ Three option slots are available for I/O extension, speed feedback, communication protocol and functional safety options.

FSO-xx can also be mounted on a DIN rail by using a separate installation kit. DIN rail mounting does not consume the drive's option slots.

²⁴⁾ Please check availability from your local ABB.

²⁵⁾ Available for R8i

По вопросам продаж и поддержки обращайтесь:

Алматы (7273)495-231
Ангарск (3955)60-70-56
Архангельск (8182)63-90-72
Астрахань (8512)99-46-04
Барнаул (3852)73-04-60
Белгород (4722)40-23-64
Благовещенск (4162)22-76-07
Брянск (4832)59-03-52
Владивосток (423)249-28-31
Владикавказ (8672)28-90-48
Владимир (4922)49-43-18
Волгоград (844)278-03-48
Вологда (8172)26-41-59
Воронеж (473)204-51-73
Екатеринбург (343)384-55-89
Иваново (4932)77-34-06
Ижевск (3412)26-03-58
Иркутск (395)279-98-46
Казань (843)206-01-48

Калининград (4012)72-03-81
Калуга (4842)92-23-67
Кемерово (3842)65-04-62
Киров (8332)68-02-04
Коломна (4966)23-41-49
Кострома (4942)77-07-48
Краснодар (861)203-40-90
Красноярск (391)204-63-61
Курган (3522)50-90-47
Курск (4712)77-13-04
Липецк (4742)52-20-81
Магнитогорск (3519)55-03-13
Москва (495)268-04-70
Мурманск (8152)59-64-93
Набережные Челны (8552)20-53-41
Нижний Новгород (831)429-08-12
Новокузнецк (3843)20-46-81
Новосибирск (383)227-86-73
Ноябрьск(3496)41-32-12

Омск (3812)21-46-40
Орел (4862)44-53-42
Оренбург (3532)37-68-04
Пенза (8412)22-31-16
Пермь (342)205-81-47
Петрозаводск (8142)55-98-37
Псков (8112)59-10-37
Ростов-на-Дону (863)308-18-15
Рязань (4912)46-61-64
Самара (846)206-03-16
Санкт-Петербург (812)309-46-40
Саранск (8342)22-96-24
Саратов (845)249-38-78
Севастополь (8692)22-31-93
Симферополь (3652)67-13-56
Смоленск (4812)29-41-54
Сочи (862)225-72-31
Ставрополь (8652)20-65-13
Сургут (3462)77-98-35

Сыктывкар (8212)25-95-17
Тамбов (4752)50-40-97
Тверь (4822)63-31-35
Тольятти (8482)63-91-07
Томск (3822)98-41-53
Тула (4872)33-79-87
Тюмень (3452)66-21-18
Улан-Удэ (3012)59-97-51
Ульяновск (8422)24-23-59
Уфа (347)229-48-12
Хабаровск (4212)92-98-04
Чебоксары (8352)28-53-07
Челябинск (351)202-03-61
Череповец (8202)49-02-64
Чита (3022)38-34-83
Якутск (4112)23-90-97
Ярославль (4852)69-52-93

Россия +7(495)268-04-70

Казахстан +7(7172)727-132

Киргизия +996(312)96-26-47

<https://abbd rives.nt-rt.ru/> || aei@nt-rt.ru