

По вопросам продаж и поддержки обращайтесь:

Самары (7273)495-231
Ангарск (3955)60-70-56
Архангельск (8182)63-90-72
Астрахань (8512)99-46-04
Барнаул (3852)73-04-60
Белгород (4722)40-23-64
Благовещенск (4162)22-76-07
Брянск (4832)59-03-52
Владивосток (423)249-28-31
Владикавказ (8672)28-90-48
Владимир (4922)49-43-18
Волгоград (844)278-03-48
Вологда (8172)26-41-59
Воронеж (473)204-51-73
Екатеринбург (343)384-55-89
Иваново (4932)77-34-06
Ижевск (3412)26-03-58
Иркутск (395)279-98-46
Казань (843)206-01-48

Калининград (4012)72-03-81
Калуга (4842)92-23-67
Кемерово (3842)65-04-62
Киров (8332)68-02-04
Коломна (4966)23-41-49
Кострома (4942)77-07-48
Краснодар (861)203-40-90
Красноярск (391)204-63-61
Курган (3522)50-90-47
Курск (4712)77-13-04
Липецк (4742)52-20-81
Магнитогорск (3519)55-03-13
Москва (495)268-04-70
Мурманск (8152)59-64-93
Набережные Челны (8552)20-53-41
Нижний Новгород (831)429-08-12
Новокузнецк (3843)20-46-81
Новосибирск (383)227-86-73
Ноябрьск (3496)41-32-12

Омск (3812)21-46-40
Орел (4862)44-53-42
Оренбург (3532)37-68-04
Пенза (8412)22-31-16
Пермь (342)205-81-47
Петрозаводск (8142)55-98-37
Псков (8112)59-10-37
Ростов-на-Дону (863)308-18-15
Рязань (4912)46-61-64
Самара (846)206-03-16
Санкт-Петербург (812)309-46-40
Саранск (8342)22-96-24
Саратов (845)249-38-78
Севастополь (8692)22-31-93
Симферополь (3652)67-13-56
Смоленск (4812)29-41-54
Сочи (862)225-72-31
Ставрополь (8652)20-65-13
Сургут (3462)77-98-35

Сыктывкар (8212)25-95-17
Тамбов (4752)50-40-97
Тверь (4822)63-31-35
Тольятти (8482)63-91-07
Томск (3822)98-41-53
Тула (4872)33-79-87
Тюмень (3452)66-21-18
Улан-Удэ (3012)59-97-51
Ульяновск (8422)24-23-59
Уфа (347)229-48-12
Хабаровск (4212)92-98-04
Чебоксары (8352)28-53-07
Челябинск (351)202-03-61
Череповец (8202)49-02-64
Чита (3022)38-34-83
Якутск (4112)23-90-97
Ярославль (4852)69-52-93

Россия +7(495)268-04-70

Казахстан +7(7172)727-132

Киргизия +996(312)96-26-47

<https://abbdrives.nt-rt.ru/> || aei@nt-rt.ru

ПРИВОДЫ ПЕРЕМЕННОГО ТОКА ВЫСОКОВОЛЬТНЫЕ Техническое описание на преобразователи частоты ACS6000



ACS6000

The right choice for high performance

The accomplished expert for heavy industries offers you unlimited possibilities of drive configurations to drive both single- and multi-motor applications. Industry-specific functions and unique features ensure reliable control of your processes and systems that require precision and high safety standards.

Modular and reliable

Well-proven modules, redundancy possibilities and a compact footprint have been instrumental in having the design of the ACS6000 commonly referred to as “best-in-class”. The drive is configured to fit with your needs and the specific conditions of your business.

The customized drive solutions deliver fast and accurate control of dynamic processes such as those found in the metals, marine and mining industries. Select from a wide range of industry-specific options and certifications (e.g. marine, offshore) to tailor the drive according to your requirements and get the optimum configuration by combining the engineered modules.

The drive’s multi-motor operation optimizes efficiency whilst reducing your costs and space requirements. Integration into your system is simple thanks to the flexible connection to the network through one or several transformers.

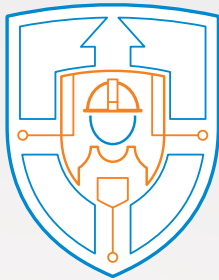

Highest level of personnel safety

Your people and goods are protected from electric arcs as the ACS6000 features an advanced arc resistant design. Certified functional safety features, an integrated DC grounding switch and door interlocking make your systems even safer and more reliable.

High reliability through well-proven design

Reliability is ensured thanks to the simple and fuseless design of the ACS6000. A low parts count and proven components result in high uptime and a long lifetime of the drive. Availability is further increased with the drive's power loss ride-through function.

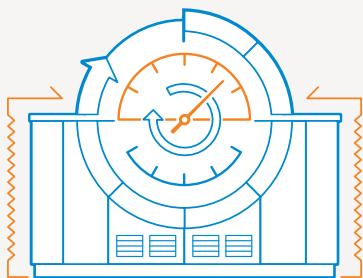
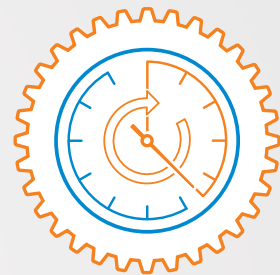

Drive robustness ensures high availability

The robust ACS6000 effortlessly drives your high power applications and controls operations even in harsh environments using the IP54 solution. Special features such as automatic restart ensure high availability of your processes.

Serviceability

Easy front access to all components ensures that service and maintenance for the ACS6000 is simple and smooth. Complete phase modules can be exchanged easily and safely. In addition to powerful diagnostic tools, you can profit by convenient remote monitoring.

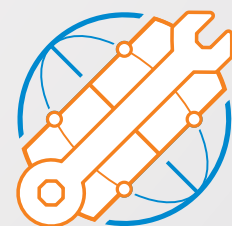

ACS6000

Flexible drive system integration



Customized solutions enable a smooth integration of the drive into any industrial environment.

Easier than you think

With its modular design, you can easily integrate the ACS6000 into any industrial environment. The drive can be optimally configured for single-motor and multi-motor applications without additional control equipment. The high power density, the compact footprint and the drive's communication abilities minimize the overall installation costs.

Flexible network connections

The ACS6000 can be connected to the network through one or several transformers depending on process, power and harmonics requirements. Optionally, the integration of a harmonic filter is possible for weak networks.

Power factor correction

The drive can also provide reactive power (VAR) compensation, controlling the voltage level to stay within tight limits. A smooth network voltage profile can be maintained and reactive power penalties can be avoided.

Control system

We offer an open communication concept, enabling connection to a Programmable Logic Controller (PLC) or a Distributed Control System (DCS). Fieldbus connectivity with a wide variety of protocols is available. The ACS6000 platform offers the possibility to monitor the transformers, as well as the motors with the drive's control system.

Commissioning

You can benefit from the ACS6000s multidrive configuration as commissioning is much faster compared to using the equivalent number of single drives. The commissioning wizard DriveStartup is an advanced tool that simplifies and speeds up commissioning. Standardized parameter sets and trained, certified professionals ensure smooth and fast commissioning.

ACS6000

More efficiency with drive packages



Packaged drive solutions provide you with ultimate efficiency and reliability to optimize your cost of ownership.

All in one package

Committed to supporting you in your business, we offer packaged drive solutions for applications in various industries. Customer-specific drive packages including medium voltage converters, motors and transformers can be developed as turnkey solutions meeting your individual requirements.

Matched performance

To ensure design integrity and an optimum match of equipment, ABB products have undergone combined tests ensuring performance predictability for your application.

Single point of contact

The combined power of the ABB offering is geared to deliver on customer expectations. We deliver motor-drive solutions that support your technical and commercial needs, from quotation, through delivery and service, over the entire product life-cycle.

Converter motors

With ABB's motors for your applications you will benefit from high versatility, reliability and simplicity.

Converter transformers

ABB offers converter transformers for all ratings, as well as for indoor or outdoor mounting. Particularly designed for operation with variable speed drives, the transformer adapts the converter to the supply network and provides a galvanic isolation between drive and supply network.

Technical features

Modular solution with unique features

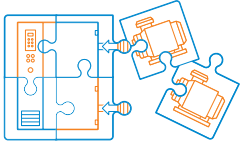

Modular drive design

The modular product platform of the ACS6000 allows the optimum configuration of any 1. The compact,

standardized design and the integrated water cooling system will reduce your space requirements and have positive impacts on your room air conditioning.

The ACS6000 is designed as a set of modules that are arranged according to the required output power, motor configuration and process needs. The use of well-proven modules minimizes the risk of design errors even when complex systems are engineered.

Depending on the application, three basic types of configurations are used.

Single-motor drive configurations

Single-motor configurations are commonly used in applications that require large, independent and decentralized drives. They are suitable for synchronous, induction and permanent magnet motors with passive or active front end.

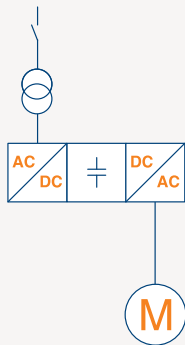

Multi-motor drive configurations

Up to eight motors can be linked to a common DC bus, enabling multiple motor and/or induction, any combination is possible in order to provide the optimum configuration with passive or active front end.

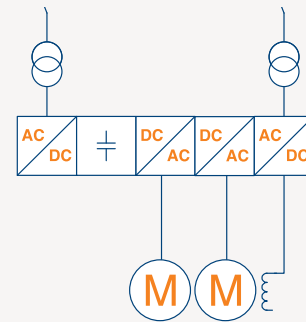

Redundant drive configurations

Single drives can be configured to allow various schemes for redundancy for motors with two winding systems. This will increase the availability of your drive system.

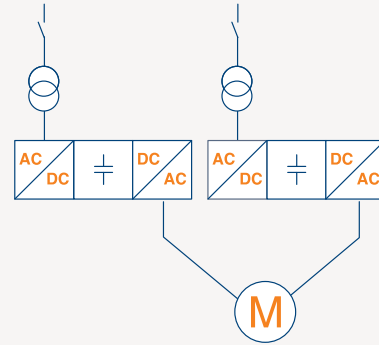



Optimized energy flow

The common DC bus allows several motors to be connected to the same DC bus, providing an optimized energy flow.

The braking energy generated in one motor can be transferred to other inverters via the common DC bus without power consumption from the supply network. Due to the near unity power factor throughout the whole speed range, the energy efficiency is optimal.

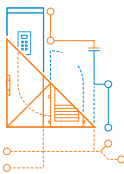

Flexible drive design

Integrating the ACS6000 into your system is simple. It can control both low and standard speed motors, enabling operation without a gearbox. Depending on your system, you can operate the drive

on one or several transformers. For special applications you can select from our broad range of options to configure your system.



Powerful performance with DTC

Fast and accurate process control in combination with low energy consumption results in top performance.

The motor control platform of the ACS6000 using Direct Torque Control (DTC) provides the highest torque and speed performance ever achieved in result, control of the drive is immediate and smooth under all conditions.



Highest level of personal and equipment safety

Electric arcs represent a hazard source for people and goods. For systems where large and dangerous arc fault currents can

occur, special attention is required. Therefore, the ACS6000 is equipped with a superior protection function and ABB's Arc Guard System™. This IAC classified solution assures very fast arc detection and elimination (less than 6 ms) to protect people and equipment and eliminate unnecessary production stops.

The ACS6000 is equipped with SIL (safety integrity level) 3 and PL (performance level) e certified functional safety features making your systems even safer and more reliable. An integrated grounding switch and door interlocking ensure the highest safety standards for your personnel.



Reliable and efficient components The combination of well-proven parts and an innovative topology results in a reliable drive solution to control your processes.

IGCT semiconductor

The ACS6000 uses a new generation of semiconductor (Integrated Gate Commutated Thyristor), which switch for high voltage medium voltage applications. use of results in a low parts count, providing an efficient and reliable drive. The low total losses of the require less cooling equipment.

Fuseless

The converter design require any medium voltage power fuses, which are known to be unreliable, costly and subject to aging. The ACS6000 provides faster and reliable protection for the power components. The protection scheme responds in less than 25 µsec, about two hundred times faster than fuses.

Power loss ride-through

A special feature of DTC is the ability to ride through short main supply voltage interruptions so that in most cases the process is not affected.

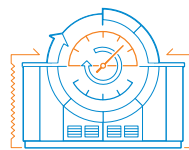

Drive robustness

Special control features of the ACS6000 drive allow reliable operation in both weak and unbalanced networks. The drive

is available with IP54 protection, making it suitable for operation even in harsh environments.

ACS6000

Water-cooled, 5 - 36 MW

Cost and energy savings are possible with a water-cooled drive system that is configured to fully meet your needs.

EMC compliant cabinet for problem-free operation in electromagnetic environment

User-friendly drive control panel for local operation

- Keypad with multi-language display
- Main supply on/off pushbuttons
- Emergency off pushbutton

DC bus grounding switch and electromechanically interlocked doors of power sections for personal safety

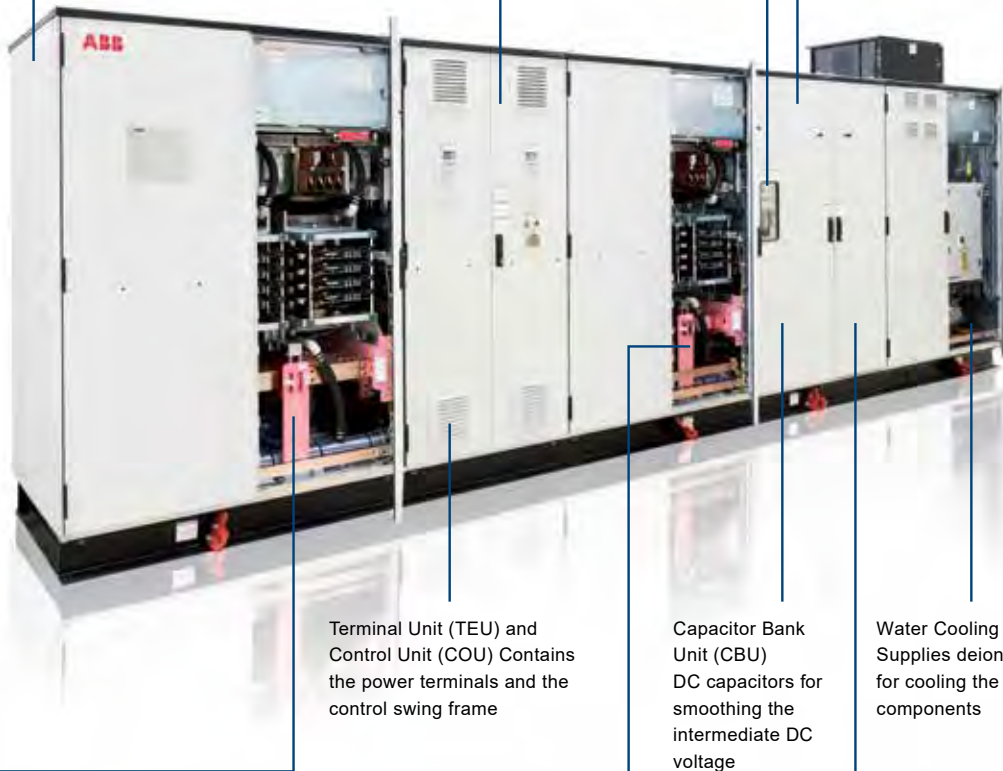

Terminal Unit (TEU) and Control Unit (COU) Contains the power terminals and the control swing frame

Capacitor Bank Unit (CBU) DC capacitors for smoothing the intermediate DC voltage

Water Cooling Unit (WCU) Supplies deionized water for cooling the main power components

Active Rectifier Unit (ARU) Self-commutated, 6-pulse, 3-level voltage source inverter with IGCT technology

Inverter unit (INU) Self-commutated, 6-pulse, 3-level voltage source inverter with IGCT technology

Voltage Limiter Unit (VLU) Optional dynamic DC voltage limiter

Power Electronic Building Block (PEBB), One phase leg of a 3-level Voltage Source Inverter (VSI) topology, which can be used both as an AC to DC or DC to AC converter



Technical data

At a glance

Input	
Input configuration	6-, 12- or 24-pulse diode rectifier 6-, 12- or 18-pulse active rectifier
Input voltage	6-pulse diode rectifier: 3300 V 12- and 24-pulse diode rectifier: 1725 V 6-, 12- and 18-pulse active rectifier: 3160 V
Input voltage variation	±10% without derating +15/-30 with derating
Input frequency	50/60 Hz
Input frequency variation	±5%
Input power factor	Diode rectifier: >0.95 Active rectifier: standard 1.0, optionally controllable
Input harmonics	Compliance with IEC61000-2-4 and IEEE 519
Auxiliary voltage	Control (optional): 110, 220 VDC or 110 – 240 VAC 50/60 Hz Auxiliary: 380 – 690 VAC 50/60 Hz, 3-phase
Output	
Output power	5000 – 36000 kW
Output voltage	2.3 – 3.3 kV
Output frequency	0 – 75 Hz (higher on request)
Motor type	Induction, synchronous and permanent magnet
Efficiency of converter	>98%
Mechanical	
Enclosure	Standard: IP32 Optional: IP42, IP54
Cable entry	Top/bottom
Environmental	
Altitude	2000 m.a.s.l. (higher with derating)
Ambient air temperature	+0 – +40 °C (lower and higher with derating)
External cooling water temperature	+5 – +32 °C (lower and higher with derating)
Noise	<75 dB (A)
Cooling type	Water
Standards	EN, IEC, CE, (optional CSA and all common marine standards)

Ratings, types and voltages ACS6000 water-

Motor data			Converter data			
Nominal rating			Type code	Power kVA	Length mm	Weight kg
kW ¹	hp ¹	A				
3300 V - induction motors, single drive with passive front end						
4300	5800	915	ACS6105-L12-1a05	5000	4900	4100
6000	8000	1300	ACS6107-L12-1a7	7000	4900	4300
7700	10300	1650	ACS6109-L12-1a9	9000	4900	4400
10000	13400	2150	ACS6114-L12-1a12	12000	6300	5300
12000	16100	2600	ACS6114-L12-2a7	14000	8600	7300
15400	20700	3300	ACS6209-L24-2a9	18000	9400	8100
20200	27100	4300	ACS6214-L24-2a12	24000	11800	9500
23200	31100	4950	ACS6214-L24-3a9	27000	13700	12600
3300 V - induction motors, single drive with active front end						
4300	5800	915	ACS6105-A06-1a05	5000	5600	4900
6000	8000	1300	ACS6107-A06-1a7	7000	5600	5100
7700	10300	1650	ACS6109-A06-1a9	9000	5600	5200
10000	13400	2150	ACS6112-A06-1a12	12000	6000	5400
12000	16100	2600	ACS6207-A12-2a7	14000	10000	9500
15400	20700	3300	ACS6209-A12-2a9	18000	10400	10300
20200	27100	4300	ACS6212-A12-2a12	24000	11200	10700
23200	31100	4950	ACS6309-A18-3a9	27000	16600	14500
3300 V - synchronous motors, single drive with passive front end						
4800	6400	915	ACS6105-L12-1s05	5000	5700	4500
6800	9100	1300	ACS6107-L12-1s7	7000	5700	4700
8700	11700	1650	ACS6109-L12-1s9	9000	5700	4800
11200	15000	2150	ACS6114-L12-1s12	12000	7100	5700
13600	18200	2600	ACS6114-L12-2s7	14000	9400	7700
17400	23300	3300	ACS6209-L24-2s9	18000	10200	8600
22400	30000	4300	ACS6214-L24-2s12	24000	10600	9900
26100	35000	4950	ACS6214-L24-3s9	27000	14500	13000
3300 V - synchronous motors, single drive with active front end						
4800	6400	915	ACS6105-A06-1s05	5000	6400	5300
6800	9100	1300	ACS6107-A06-1s7	7000	6400	5500
8700	11700	1650	ACS6109-A06-1s9	9000	6400	5600
11200	15000	2150	ACS6112-A06-1s12	12000	6800	6000
13600	18200	2600	ACS6207-A12-2s7	14000	10800	9900
17400	23300	3300	ACS6209-A12-2s9	18000	11200	10700
22400	30000	4300	ACS6212-A12-2s12	24000	12000	11100
26100	35000	4950	ACS6309-A18-3s9	27000	17400	14900
3300 V - multidrive examples with passive front end						
2 x 6000	2 x 8000	2 x 1300	ACM6207-L24-1a7-1a7	14000	8600	7450
5 x 6000	5 x 8000	5 x 1300	ACM6214-L24-1a7-1a7-1a7-1a7-1a7	28000	18900	16050
3300 V - multidrive examples with active front end						
2 x 22400	2 x 30000	2 x 4750	ACM6313-A18-2s13-2s13	36000	23600	15850
2 x 6000	2 x 8000	2 x 1300	ACM6113-A06-1a7-1a7	13000	9500	7950

Notes:

¹ Indicative information: induction motor efficiency 97.5%, power factor 0.88
synchronous motor efficiency 97.5%, power factor 1.0.

Dimensions:

Height: 2200 mm cabinet height
2500 mm incl. cooling fans on top
Depth: 1040 mm

По вопросам продаж и поддержки обращайтесь:

Самары (7273)495-231
Ангарск (3955)60-70-56
Архангельск (8182)63-90-72
Астрахань (8512)99-46-04
Барнаул (3852)73-04-60
Белгород (4722)40-23-64
Благовещенск (4162)22-76-07
Брянск (4832)59-03-52
Владивосток (423)249-28-31
Владикавказ (8672)28-90-48
Владимир (4922)49-43-18
Волгоград (844)278-03-48
Вологда (8172)26-41-59
Воронеж (473)204-51-73
Екатеринбург (343)384-55-89
Иваново (4932)77-34-06
Ижевск (3412)26-03-58
Иркутск (395)279-98-46
Казань (843)206-01-48

Калининград (4012)72-03-81
Калуга (4842)92-23-67
Кемерово (3842)65-04-62
Киров (8332)68-02-04
Коломна (4966)23-41-49
Кострома (4942)77-07-48
Краснодар (861)203-40-90
Красноярск (391)204-63-61
Курган (3522)50-90-47
Курск (4712)77-13-04
Липецк (4742)52-20-81
Магнитогорск (3519)55-03-13
Москва (495)268-04-70
Мурманск (8152)59-64-93
Набережные Челны (8552)20-53-41
Нижний Новгород (831)429-08-12
Новокузнецк (3843)20-46-81
Новосибирск (383)227-86-73
Ноябрьск (3496)41-32-12

Омск (3812)21-46-40
Орел (4862)44-53-42
Оренбург (3532)37-68-04
Пенза (8412)22-31-16
Пермь (342)205-81-47
Петрозаводск (8142)55-98-37
Псков (8112)59-10-37
Ростов-на-Дону (863)308-18-15
Рязань (4912)46-61-64
Самара (846)206-03-16
Санкт-Петербург (812)309-46-40
Саранск (8342)22-96-24
Саратов (845)249-38-78
Севастополь (8692)22-31-93
Симферополь (3652)67-13-56
Смоленск (4812)29-41-54
Сочи (862)225-72-31
Ставрополь (8652)20-65-13
Сургут (3462)77-98-35

Сыктывкар (8212)25-95-17
Тамбов (4752)50-40-97
Тверь (4822)63-31-35
Тольятти (8482)63-91-07
Томск (3822)98-41-53
Тула (4872)33-79-87
Тюмень (3452)66-21-18
Улан-Удэ (3012)59-97-51
Ульяновск (8422)24-23-59
Уфа (347)229-48-12
Хабаровск (4212)92-98-04
Чебоксары (8352)28-53-07
Челябинск (351)202-03-61
Череповец (8202)49-02-64
Чита (3022)38-34-83
Якутск (4112)23-90-97
Ярославль (4852)69-52-93

Россия +7(495)268-04-70

Казахстан +7(7172)727-132

Киргизия +996(312)96-26-47

<https://abbdrives.nt-rt.ru/> || aei@nt-rt.ru